

Infrastructure Solutions



Cabinets
Cable Management
Airflow Management
Power Distribution Units
Monitoring (Power, Environment, Access)



**Be certain.
Belden.**

Our End-to-End Expertise.
Your End-to-End Solution.



BELDEN
SENDING ALL THE RIGHT SIGNALS

Belden – the most trusted brand for reliable signal transmission solutions – offers a complete selection of cabinets, power distribution units, monitoring and airflow management products to meet your infrastructure needs for optimizing system performance.

**Be certain.
Belden.**



Belden Infrastructure Solutions

Faster. Easier. Better.

Today's Data Center professionals must ensure that their infrastructure is highly available, scalable and flexible, while at the same time control operating expenses. These conflicting objectives have drawn attention to the performance of physical infrastructure elements, including heating and cooling, rack-level power, bandwidth and physical security management – all of which impact infrastructure availability, and therefore, mission critical applications.

Belden understands the issues you face daily – cooling, power, density and security – and can help you capitalize on these opportunities by implementing the right blend of technologies to maximize the efficiency of your enterprise in a manner that complements your system's performance requirements – today and into the future.



Table of Contents

There's a Belden
Infrastructure Solution
that fits your application.



Infrastructure Solutions	Page
Table of Contents	4-5
Introduction	2-11
Markets	6
Applications	7
Application Guide	8
Product Summary and Selection Guide	9
Solutions	10-11
Section ONE – Telecommunication Room and LAN Cabinet Solutions	
E-Series LAN Cabinets	13-21
EDL – Light Data Cabinets – 400 kg	14 - 15
EDC – Compact Data Cabinets – 600 kg	16 - 17
ESN – Networking Cabinets – 1200 kg	18 - 19
EDF – Flatpack Cabinets – 800 kg	20 - 21
E-Series Wall Mount Cabinets	22-27
EWS – Single Section	22 - 23
EWR – Single Section with Removable Side Panels	24 - 25
EWD – Double Section	26 - 27
Section TWO – Data Center (DC) Solutions - Server and Switch Cabinets	
E-Series DC Cabinets	29-35
ESN – Networking and Switch Cabinets – Increased Load 1500 kg	30 - 31
ESN – Multi-tenant Colocation Cabinets – 1200 kg	32 - 33
ESH – Server and Switch Cabinet – 1800 kg	34 - 35
X-Series DC Cabinets	36-43
XN – Networking and Switch Cabinet – 1350 kg	36 - 39
XHS – Server Cabinet – 1350 kg	40 - 43
Section THREE – Components and Accessories	
19" Accessories	45-47
Horizontal Cable Managers	46
Filler Panels	47
Shelfs	47
E-Series Cabinet Accessories	48-53
Vertical Cable Manager Finger Style	48
VCM Lacing Panel and Toolless PDU holder	49
HCM Front to Rear	49
Separation Frame	50
Stability Frame incl. Cable Management	50
Fan Units with Thermostat	51
Bases	51
Grounding Bar Vertical	52
Other Accessories for E-Series	53
X-Series Cabinet Accessories	54-59
XN Cabinets	54 - 55
XHS Cabinets	56 - 59



■ Section FOUR – Controlling and Monitoring	
Power Distribution and Climate Monitoring	61 - 71
Overview	62
Cabinet Power Distribution Units (PDUs)	63
Upgradable Technology	64
Basic PDU	66
Metered PDU	67
Power Monitoring PDU	68
Switched PDUs	69
Environmental Sensors	70
Accessories	71
Aisle Containment	72 - 75
E-Series Aisle Containment Sliding Doors and Roof System	72-73
X-Series Aisle Containment	74 - 75
Access Control System for X-Series	76 - 77
■ Section FIVE – Runway Solutions	
Cable Runway	79 - 83
Junction Kits	84 - 89
Support Brackets	90 - 99
■ Warranty	
Warranty	101 - 103





We are a leading company serving a multitude of industries with a strong focus on selected markets.

Markets

The use of multiple infrastructures within the enterprise, comprised of components from any number of infrastructure vendors and installers, adds undue complexity to the buying and specifying process, as well as to the updating and management of the infrastructure.

Adding to this complexity is the fact that most infrastructure vendors are unable to provide both high-value legacy cabling solutions for autonomous systems and high-performance IP-based solutions. Unlike any other infrastructure vendor, Belden tackles these problems by taking a universal approach to the enterprise – resolving every signal transmission need with IP- and legacy-based solutions that enable a smooth migration to convergence. Our high-bandwidth, high-density copper and fiber connectivity solutions provide solutions for a diverse set of markets including:

Local Area Networks

Full compliment of innovative and highly reliable infrastructure solutions to support all LAN applications from building entrance to desktop.

Data Center

Consultative design of custom infrastructure solutions for optimal turn-up time, agility, reliability and Total Cost of Ownership.

Key Markets

- Data Hosting
- Healthcare
- Education
- Financial
- Government
- Hospitality





Applications



Industry's Most Extensive Enterprise Connectivity Portfolio

Infrastructure Solutions

- Cabinets
- Cabinet Power Distribution
- Airflow and Climate Monitoring
- Cable Management Accessories



Fiber Cable and Connectivity

- Backbone, campus, in-building and Fiber to the Desk
- Quick Deploy Pre-Term Systems
- Industry Leading Low-Loss Connectivity



Copper Cable and Connectivity

- Category systems for LAN and Data Center
- Access Control Cabling
- Building Automation and Control









Data Center Ready Solutions

- Customization and Design services
- Pre-configured and pre-installed Cable Management and Connectivity options

Application Guide for Belden Cabinets



Product Family	Page Number	 Enterprise Networking	 Data Center/ Telco	 Broadcast	 Audio Video	 Security	 Cable TV, Head End	 General Purpose
EDL (400 kg)	14 - 15	•			•		•	•
EDC (600 kg)	16 - 17	•		•	•	•	•	•
ESN (1200 kg)	18 - 19	•		•		•	•	•
EDF (800 kg Flatpack)	20 - 21	•			•			•
EWS (Wall Mount)	22 - 23	•			•	•		•
EWR (WM Side Access)	24 - 25	•			•	•		•
EWD (WM double)	26 - 27	•			•	•		•
ESN (1500 kg)	30 - 31		•	•		•	•	•
ESN Colo (1200 kg)	32 - 33		•					
ESH (1800 kg)	34 - 35		•			•		
XN (1350 kg)	36 - 39		•					
XHS (1350 kg)	40 - 43		•					
PDU	62 - 71	•	•	•	•	•	•	•
Aisle Containment	72 - 75		•					
Ladder Rack	79 - 99	•	•	•				

Engineered to meet
your specific needs.

Belden has leveraged its engineering and manufacturing expertise to bring you the most reliable cable, connectivity, cabinet and active systems solutions available – with the largest selection of products and the industry’s most trusted technical support and service.

This catalog of Infrastructure Solutions products reflects the same quality and reliability you have come to expect from Belden for the housing and storage of data, broadcast, security and other equipment. Engineered for optimal cable routing, ease of installation and maximum convenience,

Belden cabinets and accessories have also been designed to match the unique requirements of various industries and applications.

This table will help you select the Belden rack and cabinet family that best suits your specific application. If you need a custom design for a special application, please call us for assistance. Our Cable Management teams have many years of experience in modifying and customizing cabinet designs to suit many different requirements.



Product Summary and Selection Guide

Infrastructure Family	Product Family	Application	Max. Load	Page	Rack Space	Width	Depth	Equipment Mounting
LAN Cabinets	EDL	E-Series Light Cabinet	400 kg	14 - 15	15, 18, 22, 27, 32, 37, 42, 45, 47RU	600, 800 mm	600, 800, 900, 1000, 1100, 1200 mm	19, 21, 23" ****
	EDC	E-Series Compact Cabinet	600 kg	16 - 17	15, 18, 22, 27, 32, 37, 42, 45, 47RU	600 mm	600, 800, 900, 1000, 1100, 1200 mm	19"
	ESN	E-Series Networking Cabinet	1200 kg	18 - 19	15, 18, 22, 27, 32, 37, 42, 45, 47RU	600, 800 mm*	600, 800, 900, 1000, 1100, 1200 mm	19, 21, 23" ****
	EDF	E-Series Flatpack	800 kg	20 - 21	42, 47RU	600, 800 mm	800, 1000, 1200 mm	19, 21, 23" ****
Wall Mount Cabinets	EWS	Wall Mount Single Section	30 kg	22 - 23	4, 6, 9, 12, 15, 18RU	600 mm	395, 495, 595 mm	19"
	EWR	Wall Mount Side Access	30 kg	24 - 25	6, 9, 12, 15, 18RU**	600 mm	395, 495, 595 mm	19"
	EWD	Wall Mount Double Section	20-30 kg	26 - 27	4, 6, 9, 12, 15, 18RU	600 mm	295, 515, 615 mm ***	19"
DC Cabinets	ESN	E-Series Server/Network Cabinet	1500 kg	30 - 31	15, 18, 22, 27, 32, 37, 42, 45, 47RU*	600, 800 mm	600, 800, 900, 1000, 1100, 1200 mm	19"
	ESN	E-Series Colocation Cabinet	1200 kg	32 - 33	20+21, 22+22RU	600, 800 mm	600, 800, 900, 1000 mm	19"
	ESH	E-Series Server Cabinet	1800 kg	34 - 35	37, 42, 45, 47RU	600, 800 mm	800, 1000, 1200 mm	19, 21, 23" ****
	XN	X-Series Networking Cabinet	1350 kg	36 - 39	42, 45, 48RU	30"	42, 48"	19"
	XHS	X-Series Server Cabinet	1350 kg	40 - 43	42, 45, 48RU	30", 40"	42, 48"	19"

* ESN 600 mm wide version only available in 37RU and above

** EWR 18U only possible in depth of 595 mm

*** EWD Depth 295 mm only possible in 4, 6, 9U

**** Mounting width adaptable for 800 mm version

24" = 610 mm

30" = 762 mm

42" = 1067 mm

48" = 1219 mm



Solutions

Belden End-to-End Infrastructure Solutions

Whether you are considering Belden cabinets and accessories for use in a Data Center, Commercial Enterprise or other application, it's important to look at the big picture.

Chances are, you are managing a dynamic environment with evolving systems, technologies, logical architectures and new business models. You need to ensure that your infrastructure is highly available, scalable and flexible, while at the same time, you are in control of your operating expenses.

Manage Conflicting Objectives

These often conflicting objectives focus attention on the performance of physical infrastructure elements, including heating and cooling, rack-level power, bandwidth and physical security management. The challenge is that these elements typically tend to work against each other. For example, as load is increased with high-density active equipment, the system's power and cooling requirements are increased, and so are energy costs. Because these issues are directly interrelated, complications can arise from each system being manufactured, installed and supported by different vendors. That's why a systems approach for cost-effectively cooling, managing use of power and optimizing use of available space is critical.





Belden Can Help

We optimize cooling, power and density opportunities because we have expertise in all three areas, offering solutions that effectively deal with all three at the cabinet level.

Belden Offers:

- Airflow, power distribution and power- and climate-monitoring devices that effectively help with high-density computing environments
- High-density racks, cabinets, copper and optical fiber cabling system components and cable management solutions that enable maximum bandwidth and availability in an efficient footprint for better air flow and optimal use of real estate

Advantages of Belden End-to-End Infrastructure Solutions

- Greater convenience of entire solution from a single source
- Assurance that all components work together
- The most reliable product performance in the industry
- Dependable service and superior support
- The most trusted name in the industry with a large global sales and distribution network

Delivering complete
Infrastructure Solutions
to maximize efficiencies.



BELDEN
SENDING ALL THE RIGHT SIGNALS

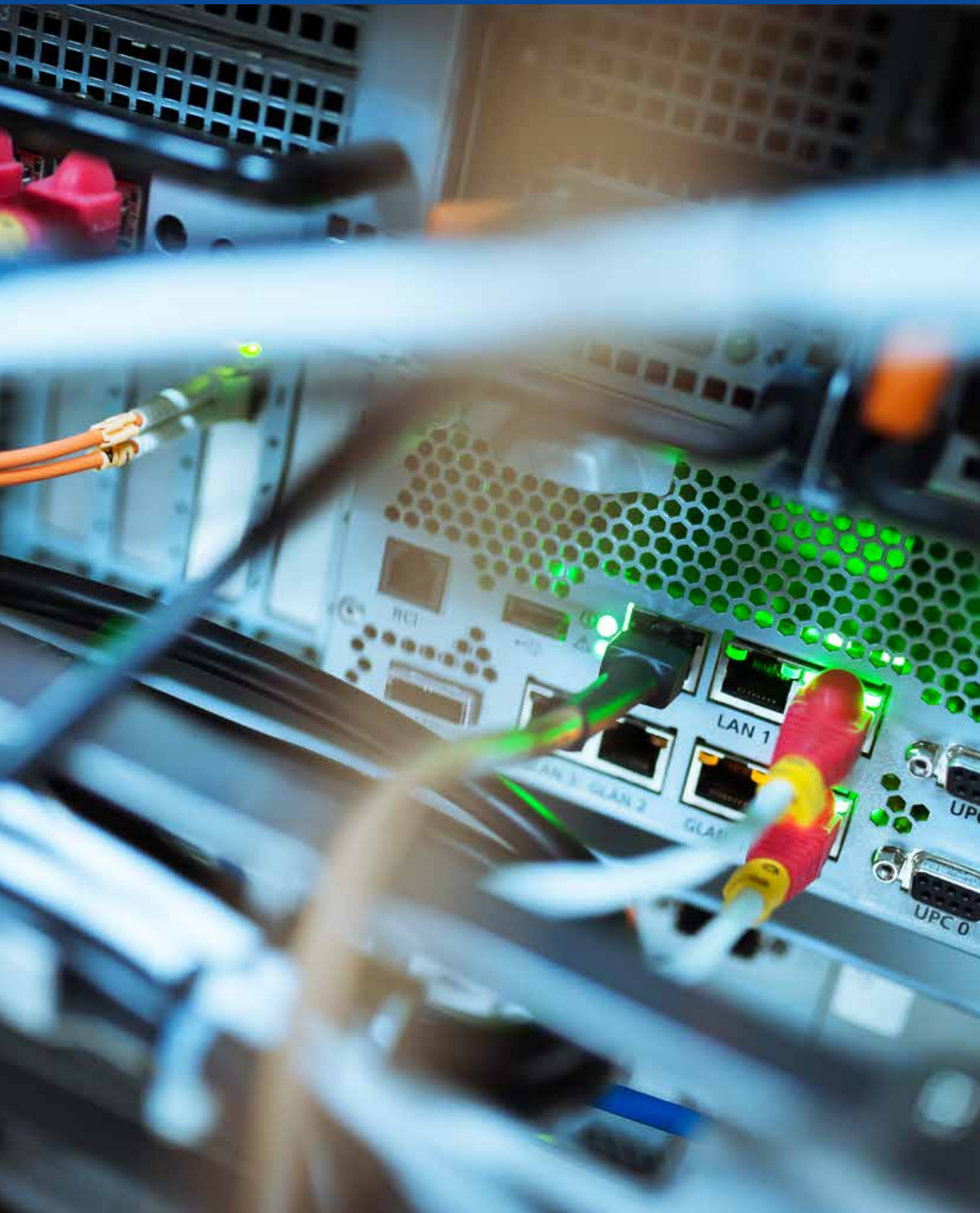



Telecommunication Room and LAN Cabinet Solutions

Section One

■ Section ONE – Telecommunication Room and LAN Cabinet Solutions

E-Series LAN Cabinets	13-21
EDL – Light Data Cabinets – 400 kg	14-15
EDC – Compact Data Cabinets – 600 kg	16-17
ESN – Networking Cabinets – 1200 kg	18-19
EDF – Flatpack Cabinets – 800 kg	20-21

E-Series Wall Mount Cabinets	22-27
EWS – Single Section	22-23
EWR – Single Section with Removable Side Panels	24-25
EWD – Double Section	26-27



E-Series LAN Cabinets

EDL – Light Data Cabinets – 400 kg

The Light Data Cabinet serie is a multipurpose cabinet for 19" Data and LAN applications. An extensive range of depths and heights are available in both 600 mm and 800 mm width.



Features

- 4 Sliding vertical rails for mounting (6 rails for cabinets deeper than 800 mm)
- Main grounding point is on the bottom of the cabinet by one M8 screw
- Top cover has knockout cut-outs for fan-unit and various cable entries
- Optional cable routing sides for between cabinets
- IP20 protection

Construction

- Welded steel frame with a maximum load capacity of 400 kg
- Frame out of Cold-rolled steel 1.3 mm
- Side panels and doors: 1.0 mm

Door and Sides

- Solid Steel door with rigid design
- Glass door with safety tempered glass of 4 mm
- Perforated door with 80% airflow with mesh pattern
- Maximum load 20 kg on the doors



Flex frame for installation of 19", 21" or 23"



Optional casters can be installed on the bottom



The hinge system allows the door to open almost 180°



Dimensions

Width (mm)	600									
Height (RU)	15	18	22	27	32	37	42	45	47	
A - Height Outer Dimension (mm)	770	900	1080	1300	1525	1750	1970	2105	2194	
B - Height Inner Door Opening (mm)	668	798	978	1198	1423	1648	1868	2003	2092	
C - Width Inner Door Opening (mm)	487									
Maximum recommended load (kg)	400 kg									
E - Depth (mm)	600 800 900 1000 1100 1200									

Width (mm)	800									
Height (RU)	15	18	22	27	32	37	42	45	47	
A - Height Outer Dimension (mm)	770	900	1080	1300	1525	1750	1970	2105	2194	
B - Height Inner Door Opening (mm)	668	798	978	1198	1423	1648	1868	2003	2092	
C - Width Inner Door Opening (mm)	687									
Maximum recommended load (kg)	400 kg									
E - Depth (mm)	600 800 900 1000 1100 1200									

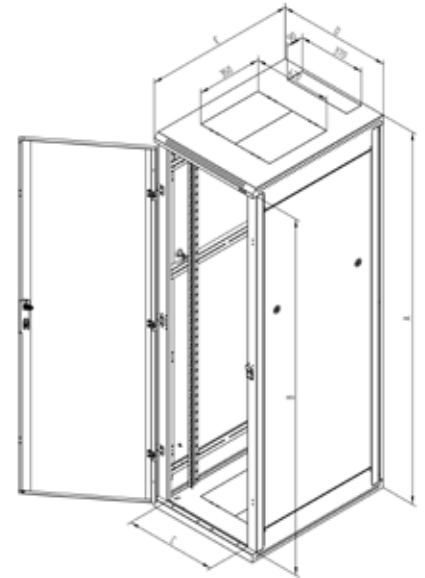

Ordering Information

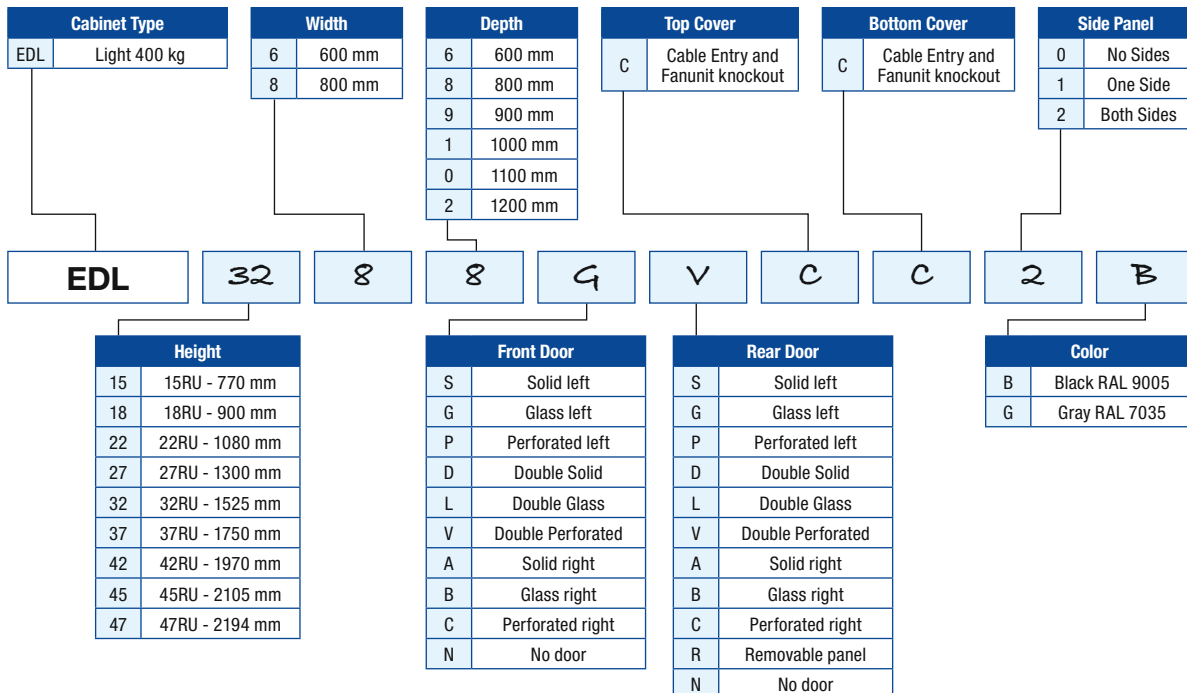

Part number example:

EDL3268GVCC2B Cabinet Light (400 kg) 32U 600 x 800 mm, Glass left door Front and Double perforated door Rear, Cable and fanunit cover, Cable and fanunit cover, 2 Removable sides (solid), Black



E-Series LAN Cabinets *(continued)*



EDC – Compact Data Cabinets – 600 kg

The Compact Data Cabinet serie is a multipurpose cabinet for 19" Data and LAN applications. An extensive range of depths and heights are available with a width of 600 mm.

Features

- 4 Sliding vertical rails for mounting
- All components interconnect with ground wire and Main grounding point on bottom (M8 stud)
- Top cover has knockout cut-outs for fan-unit and various cable entries
- Optional cable routing sides for between cabinets
- Enlarged skeleton rails allows installation of accessories - PDU, cable and patch cord management
- Square perforation in the frame for captive nuts alongside the height of the rail in the unit span allows additional accessory installation
- 19" vertical rails (zinc-coated 2 mm cold-rolled steel) are laser marked at every installation unit (RU)
- IP20 protection

Construction

- Welded steel frame with a maximum load capacity of 600 kg
- Strengthened frame out of Cold-rolled steel 1.3 mm
- Sliding rail (fixed at four points): Cold-rolled steel 2.0 mm
- Side panels and doors: 1.0 mm

Door and Sides

- Solid Steel door with rigid design
- Glass door with safety tempered glass of 4 mm
- Perforated door with 80% airflow with mesh pattern
- Maximum load 20 kg on the doors
- Side panels with optional extra cable entries
- Side mounted with security screws options

Vertical Lacing Panel / PDU holder

- Lacing panel available for easy in corner cable management
- Lacing for cable bundles
- Tool less PDU mounting

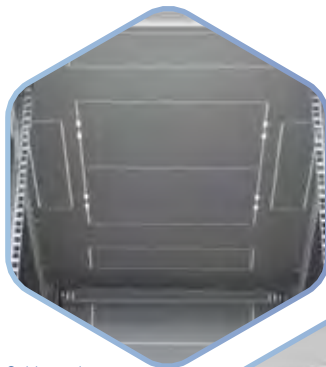

Cable entries and Fan in top cover



Perforated frame for additional accessories



Multiple cable entry options



Dimensions

Width (mm)	600								
Height (RU)	15	18	22	27	32	37	42	45	47
A - Height Outer Dimension (mm)	770	900	1080	1300	1525	1750	1970	2105	2194
B - Height Inner Door Opening (mm)	668	798	978	1198	1423	1648	1868	2003	2092
C - Width Inner Door Opening (mm)	487								
Maximum recommended load (kg)	600 kg								
E - Depth (mm)	600 800 900 1000 1100 1200								

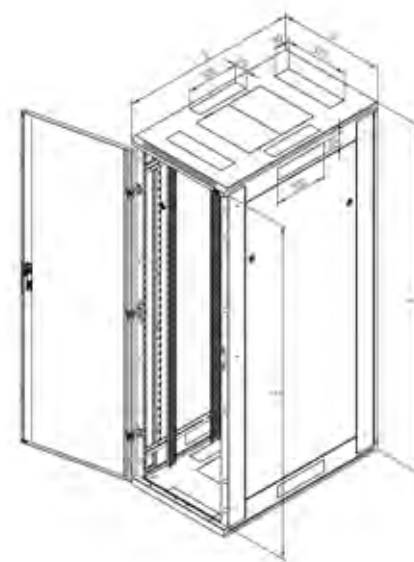

Ordering Information

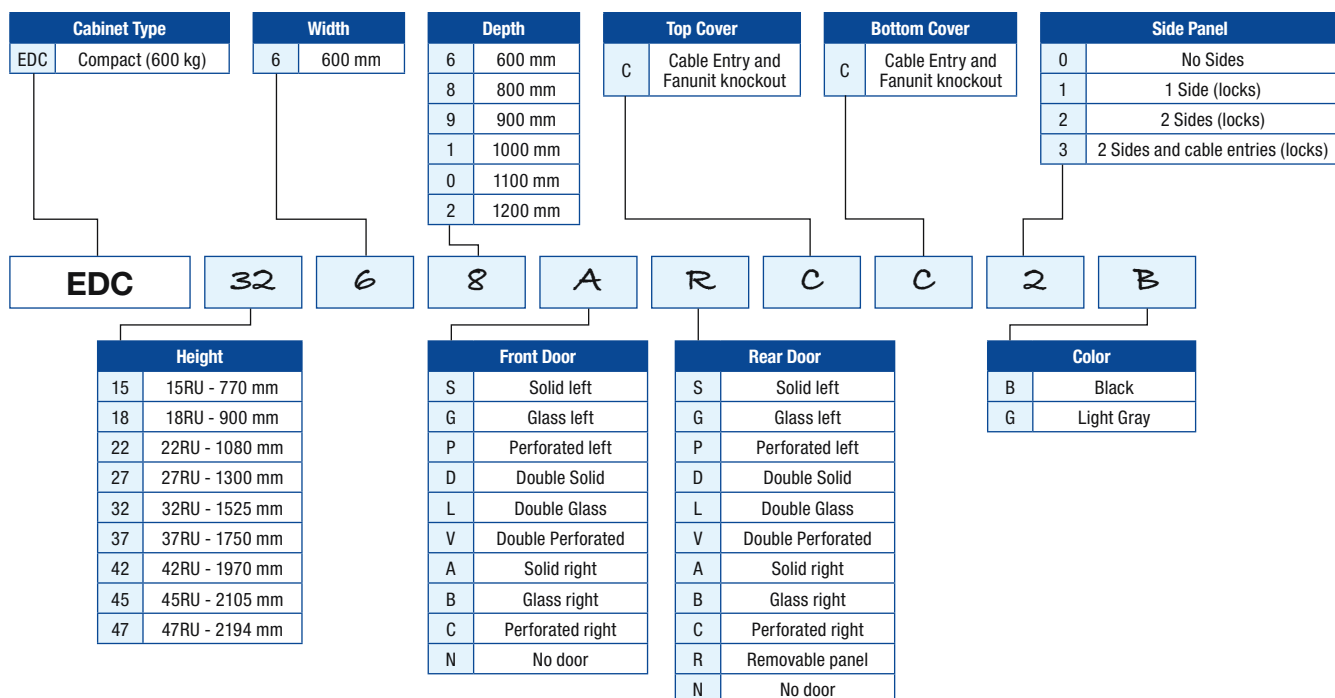

Part number example:

EDC2768ARCC2B Cabinet 27U 600x 800 mm, Solid right door Front and Removable panel Rear, Cable and fanunit cover, Cable and fanunit cover, 2 Sides (locks), Black



E-Series LAN Cabinets *(continued)*



ESN – Server and Networking Cabinets – 1200 kg

With a high load (1200 kg) and numerous features this range is most suitable for Data, Telecommunications, LAN and Switching / Server applications. Varying depths and heights are available for various applications.

Features

- 4 Sliding vertical rails for mounting (6 rails for cabinets deeper than 800 mm)
- All components interconnect with ground wire and Main grounding point on bottom (M8 stud)
- Top cover has knockout cut-outs for fan-unit and various cable entries
- The frame is connected to the removable parts with grounding wires
- Optional cable routing sides for between cabinets
- IP20 protection

Construction

- The maximum load capacity is 1200 kg
- Strengthened frame: Cold-rolled steel 1.3 mm
- Sliding rail (fixed at four points): Cold-rolled steel 2.0 mm
- Side panels and doors: 1.0 mm

Door and Sides

- Solid Steel door with rigid design
- Glass door with safety tempered glass of 4 mm
- Perforated door with 80% airflow with mesh pattern
- Maximum load 20 kg on the doors
- Side panels with optional extra cable entries (options C3 and A5)
- Side mounted panels with security screws (options A4 and A5)

Vertical Lacing Panel / PDU Holder

- Lacing panel available for easy in corner cable management
- Lacing for cable bundles
- Tool less PDU mounting

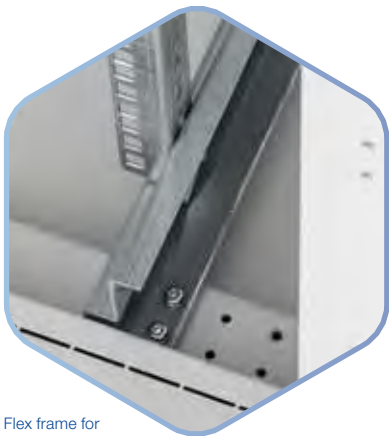

Flex frame for installation of 19", 21" or 23"

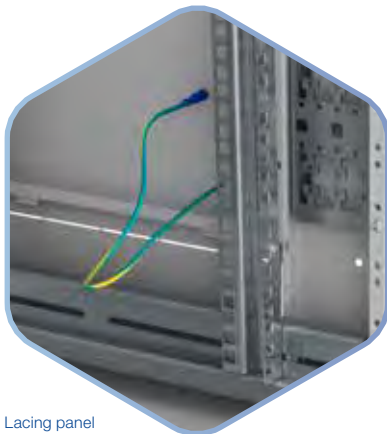

Lacing panel accessory installed



Perforated frame for additional accessories



Dimensions

Width (mm)	600				800								
Height (RU)	37	42	45	47	15	18	22	27	32	37	42	45	47
A - Height Outer Dimension (mm)	1750	1970	2105	2194	770	900	1080	1300	1525	1750	1970	2105	2194
B - Height Inner Door Opening (mm)	1648	1868	2003	2092	668	798	978	1198	1423	1648	1868	2003	2092
C - Width Inner Door Opening (mm)	487				687								
Maximum recommended load (kg)	1200 kg												
E - Depth (mm)					600	800	900	1000	1100	1200			

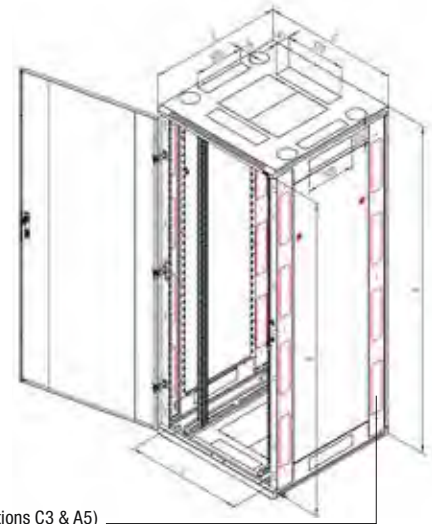

Extra Cable Entries (options C3 & A5)

Ordering Information

Cabinet Type		Width		Depth		Bottom Cover*		Side Panels		Variant
ESN	Server Networking 1200 kg	6	600 mm	6	600 mm	C 0	Cable Entry and Fanunit knockout	No Sides		LAN
	*ESN 800W 37U+ Upgradable to 1500 kg	8	800 mm	8	800 mm	C 1	Cable Entry and Fanunit knockout	1 Side (locks)		LAN
				9	900 mm	C 2	Cable Entry and Fanunit knockout	2 Sides (locks)		LAN
				1	1000 mm	C 3	Cable Entry and Fanunit knockout	2 Sides and Cable entries (locks)		LAN
				0	1100 mm	A 0	Large air inlet and cable entry	No Sides		Data Centre
				2	1200 mm	A 4	Large air inlet and cable entry	2 Sides (screws)		Data Centre
						A 5	Large air inlet and cable entry	2 Sides and Cable entries (screws)		Data Centre

ESN	42	8	1	G	S	C	C	3	G
------------	-----------	----------	----------	----------	----------	----------	----------	----------	----------

Height *		Front Door		Rear Door		Top Cover		Color	
15	15RU - 770 mm *	S	Solid left	S	Solid left	C	Cable Entry and Fanunit knockout	B	Black
18	18RU - 900 mm *	G	Glass left	G	Glass left			G	Light Gray
22	22RU - 1080 mm *	P	Perforated left	P	Perforated left				
27	27RU - 1300 mm *	D	Double Solid	D	Double Solid				
32	32RU - 1525 mm *	L	Double Glass	L	Double Glass				
37	37RU - 1750 mm *	V	Double Perforated	V	Double Perforated				
42	42RU - 1970 mm *	A	Solid right	A	Solid right				
45	45RU - 2105 mm *	B	Glass right	B	Glass right				
47	47RU - 2194 mm *	C	Perforated right	C	Perforated right				
		N	No door	N	No door				

Notes:

- ESN 800 mm wide version with 37RU and above can be upgraded to 1500 kg by ordering reinforcement kit EDASR
- ESN 600 mm wide version **only** available in 37RU and above
- Perforated doors have 80% openings by Mesh pattern
- Bottom Cover "C" for LAN variant, "A" for Data Centre variant

Part number example:

ESN4281GSCC3G Cabinet Server and Networking (1200 kg) 42U 800 x 1000 mm, Glass left door Front and Solid left door Rear, Cable and fanunit cover, Cable and fanunit cover, 2 Sides and Cable entries (locks), Light Gray





E-Series LAN Cabinets *(continued)*

EDF – Flatpack Cabinets – 800 kg

The Flatpack Cabinet serie reduces shipping and storage costs, easy installation in areas with limited access. Cabinet package is composed out of three carton boxes: Two door and one middle frame.



Features

- 4 Sliding vertical rails for mounting
- Main grounding point is on the bottom of the cabinet by one M8 screw
- Top cover has knockout cut-outs for fan-unit and various cable entries
- Reinforced vertical rails are fully adjustable to the depth of the cabinet. Marks on sliding rails simplify the alignment of all verticals
- IP20 protection

Door and Sides

- Solid Steel door with rigid design
- Glass door with safety tempered glass of 4 mm
- Perforated door with 80% airflow with mesh pattern
- Maximum load 20 kg on the doors

Easy installation

A system of interlocking joints together with self-threading screws makes easy assembly while maintaining high rigidity of the cabinet. Installation instructions are provided.

Construction

- This sturdy cabinet structure, based on the strong welded door frames, is able to safely carry a load of 800 kg
- In the 800 mm cabinets, reinforced vertical rails can be installed with a spacing of 19", 21" and even 23"
- Frame out of Cold-rolled steel 1.3 mm
- Side panels and doors: 1.0 mm



Flex frame for installation of 19", 21" or 23"



Easy installation



Rigid design



1U space inside the frame to optimize cabinet volume for e.g. PDUs



Dimensions

Width (mm)	600		800	
Height (RU)	42	47	42	47
Height Outer Dimension (mm)	2000	2200	2000	2200
Height Inner Door Opening (mm)	1880	2080	1880	2080
Maximum recommended load (kg)	800 kg			
Depth (mm)	800 1000 1200			

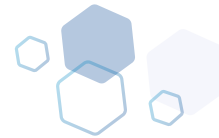
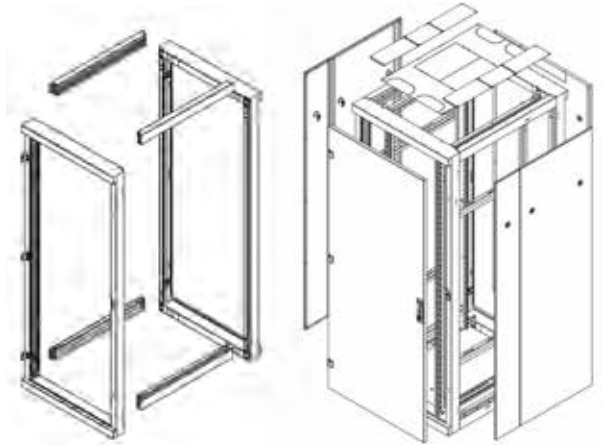

Ordering Information

Enclosure Type		Width		Depth		Top Cover		Bottom Cover		Side Panel	
EDF	Datastyle Flatpack	6	600 mm	8	800 mm	2	Cable Entry Cover	0	No Bottom Cover	2	Both Sides
		8	800 mm	1	1000 mm						
				2	1200 mm						
EDF	42	8	8	3	4	2	0	2	2		
	Height			Front Door	Rear Door				Color		
	42	42RU - 2000 mm		1	1	Solid left	1	1	1	Light Gray RAL 7035	
	47	47RU - 2000 mm		2	2	Glass left	2	2	2	Black RAL 9005	
				3	3	Perforated left	3	3	3		
				4	4	Double Solid	4	4	4		
				5	5	Double Glass	5	5	5		
				6	6	Double Perforated	6	6	6		

Notes:

- Double doors (options 4,5,6) are not available for 600 mm width, but can only be selected for 800 mm wide enclosure
- Doors 1, 2 and 3 are hinged as standard on the left side
- Enclosures standard supplied with Two Side Panels, Cable Entry Top Cover and No Bottom Cover

Part number example

EDF4288342022 Flatpack 42U 800 x 800 mm, Perforated left door Front and Double solid door Rear, Cable Entry Top cover, No Bottom cover, 2 Removable sides (solid), Black

Delivery Note

An order on Flatpack part number is confirmed with three part numbers and delivered in three boxes (2 x Door Frame and 1 x Middle Frame)



E-Series Wall Mount Cabinets



EWS – Single Section

Belden Wall Mount Cabinets for use in 19" Data, Telecommunications and Networking applications. This basic range is suitable to build in the wall when no rear or side access is required and space can be saved.

Features

- One pair of vertical 19" rails is freely adjustable in any depth of the cabinet. This simplifies mounting of devices and organisation of connecting cables
- All components interconnect with ground wire and Main grounding point on bottom (M8 stud)
- Optical knock outs available on top and bottom for fan and cable entries
- IP30 protection

Door and Sides

- The cabinet has fully glass door in standard. It can be steel or perforated if required
- The hinge system allows the door to open almost 180°. The door can be easily removed and re-mounted to change the direction of opening
- The cabinet is typically build in a wall when no side access is required

Construction

- Welded steel frame with a maximum load capacity of 30 kg



One pair fully adjustable vertical rails



Lockable door



Knock-outs for fans and cable entries



Dimensions

Width (mm)	600					
Height (RU)	4	6	9	12	15	18
A - Height Outer Dimension (mm)	280	370	500	635	770	900
B - Height Inner Door Opening (mm)	175	265	395	530	665	795
C - Width Inner Door Opening (mm)	516					
R1 - Mounting points vertical (mm)	234	324	454	589	724	854
R2 - Mounting points horizontal (mm)	420					
Recommended load (kg)	30					

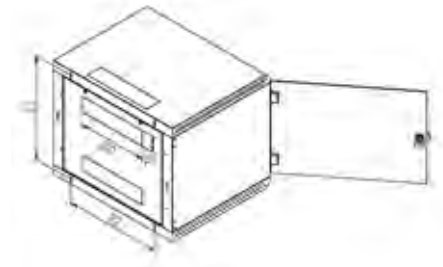
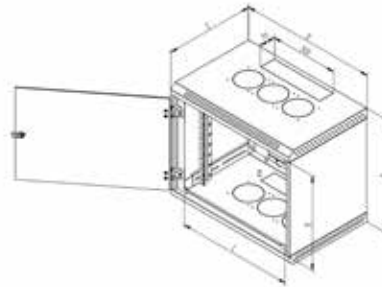
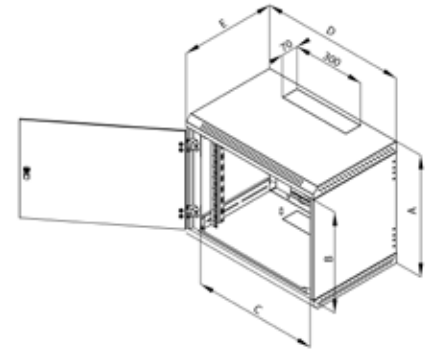

Ordering Information

Cabinet Type		Depth		Knock-out Panels	
EWS	Wall Mount Single Section Permanent Sides	4	395 mm	C	Cable Entry
		5	495 mm	F	Cable Entry and Fan Cutouts
		6	595 mm		

EWS	18	-	6	S	X	-	F	-	G
------------	-----------	---	----------	----------	----------	---	----------	---	----------

Height		Door Type		Color	
04	4RU - 280 mm	S	Solid right/left	G	Light Gray RAL 7035
06	6RU - 370 mm	G	Glass right/left	B	Black RAL 9005
09	9RU - 500 mm	P	Perforated right/left		
12	12RU - 635 mm				
15	15RU - 770 mm				
18	18RU - 900 mm				

Part number example:

EWS18-6SX-F-G Wall mount Cabinet Single section Permanent sides 18RU High 600 x 595 mm deep, Solid door, Cable Entry and loose Fans cover, Light Gray, max. load: 30 kg



E-Series Wall Mount Cabinets *(continued)*



EWR – Single Section with Removable Side Panels

Belden Cabinets for use in 19" Data, Telecommunications and Networking applications. While installed to the wall, the one sectioned cabinet has removable side panels for easy access and maintenance.

Features

- IP30 protection
- Welded frame construction
- Max. load capacity up to 30 kg
- Removable side panels for easy access
- Two pairs adjustable sliding vertical mounting rails

Door and Sides

- The cabinet has fully glass door in standard. It can be steel or perforated if required
- The hinge system allows the door to open almost 180°. The door can be easily removed and re-mounted to change the direction of opening
- Removable side panels provide easy side access

Construction

- Welded steel frame with a maximum load capacity of 30 kg



Removable sides provide easy access



Proper vertical supports for 19" equipment



Knockouts available for Cable entry and fan installation





Dimensions

Width (mm)	600				
Height (RU)	6	9	12	15	18
A - Height Outer Dimension (mm)	370	500	635	770	900
B - Height Inner Door Opening (mm)	265	395	530	665	795
C - Width Inner Door Opening (mm)	530				
R1 - Mounting points vertical (mm)	234	454	589	724	854
R2 - Mounting points horizontal (mm)	420				
Recommended load (kg)	30				

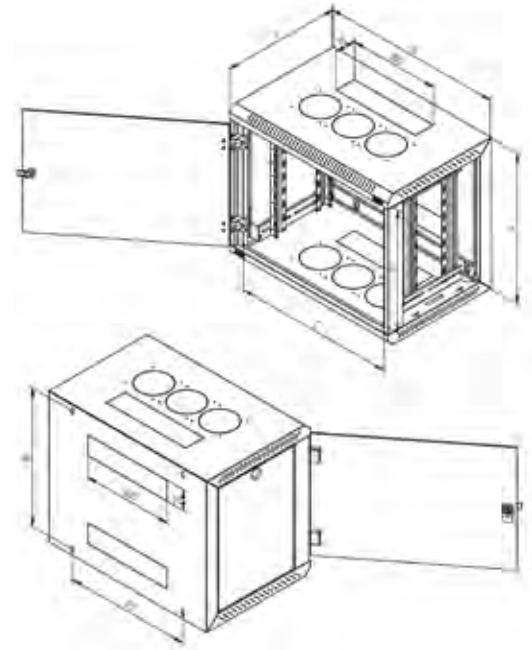

Ordering Information

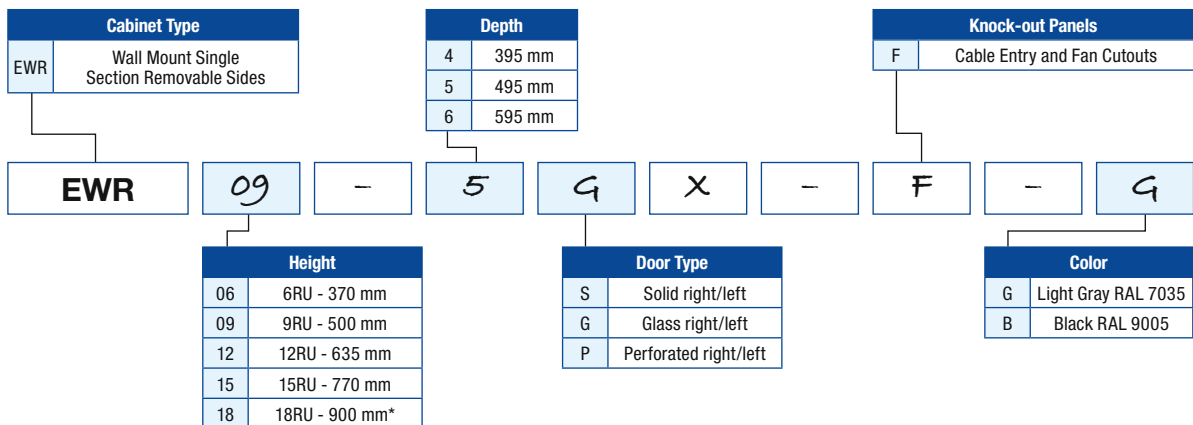

Notes:

- height (18) 18RU not possible in Depth (6) 595 mm

Part number example:

EWR09-5GX-F-G Wall mount Cabinet Single section Removable sides 09RU High 600 x 495 mm deep, Glass door, Cable Entry and loose Fans cover, Light Gray, max. load: 30 kg



E-Series Wall Mount Cabinets *(continued)*



EWD – Double Section

Belden Cabinets for use in 19" Data, Telecommunications and Networking applications. Varying depths are available for various applications. While installed to the wall, the double sectioned cabinet can be hinged open for easy access to its rear section.

Features

- IP30 protection
- Welded frame construction
- On the side of the wall mount cabinet a lock grants access to the inside of the cabinet. The section can be unlocked with the same key as the front door
- Available in 295, 515 and 615 mm depth
- One set of adjustable sliding vertical mounting rails

Door and Sides

- The cabinet has fully glass door in standard. It can be steel or perforated if required
- The hinge system allows the door to open almost 180°. The door can be easily removed and re-mounted to change the direction of opening



Construction

- Welded steel frame with a maximum load capacity of between 20 and 30 kg



Lockable door



Double section for easy rear access while installed on the wall



Perforated frame for additional accessories



Dimensions

Width (mm)	600					
Height (RU)	4	6	9	12	15	18
A - Height Outer Dimension (mm)	280	370	500	635	770	900
B - Height Inner Door Opening (mm)	175	265	395	530	665	795
C - Width Inner Door Opening (mm)	516					
R1 - Mounting points vertical (mm)	234	324	454	589	724	854
R2 - Mounting points horizontal (mm)	420					
E - Depth (mm)	295, 515, 615			515, 615		

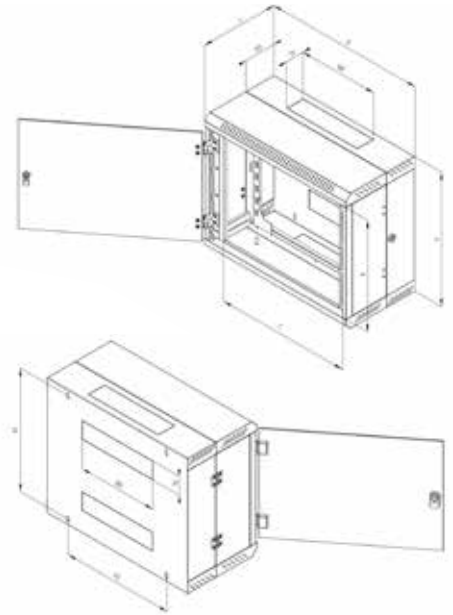

Ordering Information

Cabinet Type		Depth		Knock-out Panels	
EWD	Wall Mount Double section	3	295 mm*	C	Cable Entry
		5	515 mm	F	Cable Entry and Fan Cutouts
		6	615 mm		

EWD	06	-	3	P	X	-	C	-	B
------------	-----------	----------	----------	----------	----------	----------	----------	----------	----------

Height		Door Type		Color	
04	4RU - 280 mm	S	Solid right/left	G	Light Gray RAL 7035
06	6RU - 370 mm	G	Glass right/left	B	Black RAL 9005
09	9RU - 500 mm	P	Perforated right/left		
12	12RU - 635 mm				
15	15RU - 770 mm				
18	18RU - 900 mm				

Notes:

- Depth (3) 295 mm only available in 4, 6 and 9 Rack Units height

Part number example:

EWD06-3PX-C-B Wall mount Cabinet Double section 06RU High 600 x 295 mm deep, Perforated door, Cable Entry cover, Black, max. load: 25 kg





Data Center Solutions Server and Switch Cabinets

Section Two

■ Section TWO – Data Center (DC) Solutions - Server and Switch Cabinets

E-Series DC Cabinets	29-35
ESN – Networking and Switch Cabinets – Increased Load 1500 kg	30-31
ESN – Multi-tenant Colocation Cabinets – 1200 kg	32-33
ESH – Server and Switch Cabinet – 1800 kg	34-35
X-Series DC Cabinets	36-43
XN – Networking and Switch Cabinet – 1350 kg	36-39
XHS – Server Cabinet – 1350 kg	40-43



E-Series DC Cabinets



ESN – Networking and Switch Cabinets – 1500 kg

For the ESN cabinets with a width of 800 mm and a height of 37RU and above an upgrade kit is available to extend the maximum permissible load from 1200 kg to 1500 kg. The stability frame is a recommended reinforcement for extra stability when the 800 mm Cabinet is standing alone (not bayed) and is loaded multiple sliding servers.

Features

- 4 Sliding vertical rails for mounting (6 rails for cabinets deeper than 800 mm)
- All components interconnect with ground wire and Main grounding point on bottom (M8 stud)
- Top cover has knockout cut-outs for fan-unit and various cable entries
- The frame is connected to the removable parts with grounding wires
- Optional cable routing sides for between cabinets
- IP20 protection

Construction

- The maximum load capacity is 1200 kg
- Strengthened frame: Cold-rolled steel 1.3 mm
- Sliding rail (fixed at four points): Cold-rolled steel 2.5 mm
- Side panels and doors: 1.0 mm

Door and Sides

- Solid Steel door with rigid design
- Glass door with safety tempered glass of 4 mm
- Perforated door with 80% airflow with mesh pattern
- Maximum load 20 kg on the doors
- Side panels with optional extra cable entries
- Side mounted with security screws options

Vertical Lacing Panel / PDU Holder

- Lacing panel available for easy in corner cable management
- Lacing for cable bundles
- Tool less PDU mounting

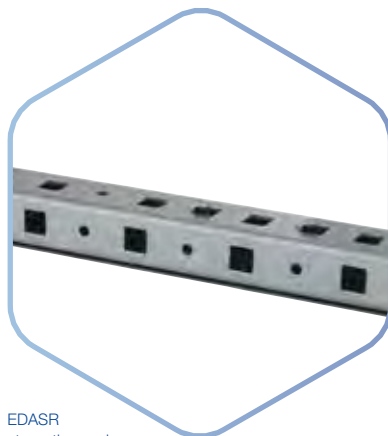
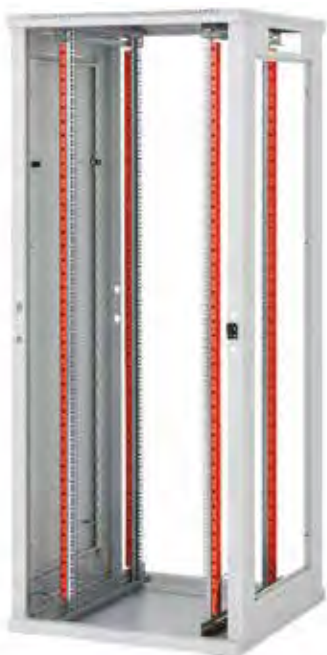

EDASR strength member





Dimensions

Width (mm)	600				800								
Height (RU)	37	42	45	47	15	18	22	27	32	37	42	45	47
A - Height Outer Dimension (mm)	1750	1970	2105	2194	770	900	1080	1300	1525	1750	1970	2105	2194
B - Height Inner Door Opening (mm)	1648	1868	2003	2092	668	798	978	1198	1423	1648	1868	2003	2092
C - Width Inner Door Opening (mm)	487				687								
Maximum recommended load (kg)	1500 kg												
E - Depth (mm)					600	800	900	1000	1100	1200			

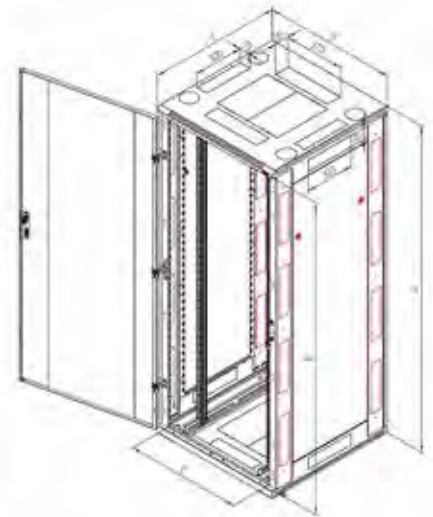

Ordering Information Reinforcement Kit

EPN	Full description BPCS and Label
EDASR037	ESN Reinforcement kit 37U Upgrade 1500 kg
EDASR042	ESN Reinforcement kit 42U Upgrade 1500 kg
EDASR045	ESN Reinforcement kit 45U Upgrade 1500 kg
EDASR047	ESN Reinforcement kit 47U Upgrade 1500 kg

Ordering Information Cabinet

Cabinet Type		Width		Depth		Bottom Cover*		Side Panels		Variant
ESN	Server Networking 1200 kg	6	600 mm	6	600 mm	C 0	Cable Entry and Fanunit knockout	No Sides		LAN
	*ESN 800W 37U+ Upgradable to 1500 kg	8	800 mm	8	800 mm	C 1	Cable Entry and Fanunit knockout	1 Side (locks)		LAN
				9	900 mm	C 2	Cable Entry and Fanunit knockout	2 Sides (locks)		LAN
				1	1000 mm	C 3	Cable Entry and Fanunit knockout	2 Sides and Cable entries (locks)		LAN
				0	1100 mm	A 0	Large air inlet and cable Entry	No Sides		Data Centre
				2	1200 mm	A 4	Large air inlet and cable Entry	2 Sides (screws)		Data Centre
						A 5	Large air inlet and cable Entry	2 Sides and Cable entries (screws)		Data Centre

ESN	42	8	8	G	V	C	C	2	G
-----	----	---	---	---	---	---	---	---	---

Height *		Front Door		Rear Door		Top Cover		Color	
15	15RU - 770 mm*	S	Solid left	S	Solid left	C	Cable Entry and Fanunit knockout	B	Black
18	18RU - 900 mm*	G	Glass left	G	Glass left			G	Light Gray
22	22RU - 1080 mm*	P	Perforated left	P	Perforated left				
27	27RU - 1300 mm*	D	Double Solid	D	Double Solid				
32	32RU - 1525 mm*	L	Double Glass	L	Double Glass				
37	37RU - 1750 mm	V	Double Perforated	V	Double Perforated				
42	42RU - 1970 mm	A	Solid right	A	Solid right				
45	45RU - 2105 mm	B	Glass right	B	Glass right				
47	47RU - 2194 mm	C	Perforated right	C	Perforated right				
		N	No door	R	Removable panel				
				N	No door				

Notes:

- ESN 800 mm wide version with 37RU and above can be upgraded to 1500 kg by ordering reinforcement kit EDASR
- ESN 600 mm wide version **only** available in 37RU and above
- Perforated doors have 80% openings by Mesh pattern
- Bottom Cover "C" for LAN variant, "A" for Data Centre variant

Part number example:

ESN4288GVCC2G Cabinet Server and Networking (1200 kg) 42U 800x 800 mm, Glass left door Front and Double perforated door Rear, Cable and fanunit cover, Cable and fanunit cover, 2 Sides (locks), Light Gray
 EDASR042 ESN Reinforcement kit 42U Upgrade 1500 kg



E-Series DC Cabinets *(continued)*



ESN – Multi-tenant Colocation Cabinet – 1200 kg

The ESN cabinet can be manufactured in a two compartment configuration for Colocation applications. This makes the cabinet versatile, to fit multi-tenant applications.

Features

- 4 Sliding vertical rails for mounting (6 rails for cabinets deeper than 800 mm)
- Divider is physically sealed off, each compartment has its own verticals
- All components interconnect with ground wire and Main grounding point on bottom (M8 stud)
- Top cover has knockout cut-outs for fan-unit and various cable entries
- The frame is connected to the removable parts with grounding wires
- Optional cable routing sides for between cabinets
- IP20 protection

Construction

- The maximum load capacity is 1200 kg
- Strengthened frame: Cold-rolled steel 1.3 mm
- Sliding rail (fixed at four points): Cold-rolled steel 2.0 mm
- Side panels and doors: 1.0 mm

Colocation

- Colocation cabinets sacrifice 1U for the split to completely seal of the compartment
- 42U cabinets have two compartments: 20U and 21U
- 45U cabinets have two compartments: 22U and 22U
- Only cable entry knockout panels can be removed from the divider



Cabinets are prepared with in-frame ventilation



All removable parts are bonded together



Dimensions

Width (mm)	600		800	
Height (RU)	37	47	15	47
A - Height Outer Dimension (mm)	1970	2105	1970	2105
B - Height Inner Door Opening (mm)	1868	2003	1868	2003
C - Width Inner Door Opening (mm)	487		687	
Maximum recommended load (kg)	1200 kg			
E - Depth (mm)	600 800 900 1000			

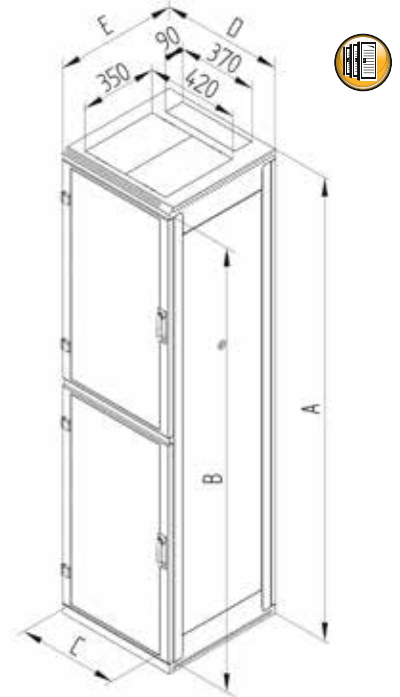

Ordering Information

Cabinet Type		Width		Depth		Top Cover		Bottom Cover		Side Panel	
ESN	Server Networking 1200 kg	6	600 mm	6	600 mm	C	Cable Entry and Fanunit knockout	C	Cable Entry and Fanunit knockout	0	No Sides
		8	800 mm	8	800 mm					1	One Side
				9	900 mm					2	Both Sides
				1	1000 mm					3	Extra Cable entries

ESN	42	8	1	G	P	C	C	2	G	2
------------	-----------	----------	----------	----------	----------	----------	----------	----------	----------	----------

Height		Front Door		Rear Door		Color		Colocation postfix	
42	21RU + 20RU - 1970 mm	S	Solid left	S	Solid left	B	Black RAL 9005	2	2 Compartments
45	22RU + 22RU - 2105 mm	G	Glass left	G	Glass left	G	Gray RAL 7035		
		P	Perforated left	P	Perforated left				
		D	Double Solid	D	Double Solid				
		L	Double Glass	L	Double Glass				
		V	Double Perforated	V	Double Perforated				
		A	Solid right	A	Solid right				
		B	Glass right	B	Glass right				
		C	Perforated right	C	Perforated right				
		N	No door	R	Removable panel				
				N	No door				

Notes:

- Colocation cabinets sacrifice 1U for the split of the compartments:
 - 42U will have two compartments (21U and 20U)
 - 45U will have two compartments (22U and 22U)
- Perforated doors have 80% openings by Mesh pattern

Part number example:

ESN4281GPCC2G2 Cabinet Server and Networking Colocation (1200 kg) 22U + 21U 800 x 1000 mm, Glass left door Front and Perforated door Rear, Cable and fanunit cover, Cable and fanunit cover, 2 Sides (locks), Light Gray



E-Series DC Cabinets *(continued)*

ESH – Server Cabinet 1800 kg

Belden Cabinets for use in 19" Data, Telecommunications and Server applications. Varying depths are available for various applications.

Features

- 4 Sliding vertical rails for mounting (6 rails for cabinets deeper than 800 mm)
- Main grounding point is on the bottom of the cabinet by one M8 screw
- Top cover has knockout cut-outs for fan-unit and various cable entries
- The frame is connected to the removable parts with grounding wires
- The maximum permissible load is 1800 kg
- Optional cable routing sides for between cabinets
- Optional lacing panel and PDU holder
- IP20 protection

Construction

- The maximum load capacity is 1800 kg
- Reinforced construction made of thicker material
- 19" vertical rails are designed for a higher loading capacity
- Cabinets with depth over 800 mm has a central pair of vertical rails as a standard solution

Door and Sides

- Solid Steel door with rigid design
- Glass door with safety tempered glass of 4 mm
- Perforated door with 80% airflow with mesh pattern
- Maximum load 20 kg on the doors
- Side panels with optional extra cable entries
- Side mounted with security screws options

Vertical Lacing Panel / PDU Holder

- Lacing panel available for easy in corner cable management
- Lacing for cable bundles
- Tool less PDU mounting



Lacing panel accessory installed

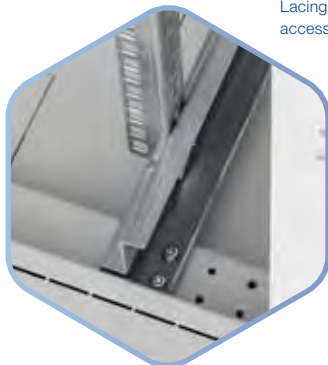

Flex frame for installation of 19", 21" or 23"



Perforated frame for additional accessories

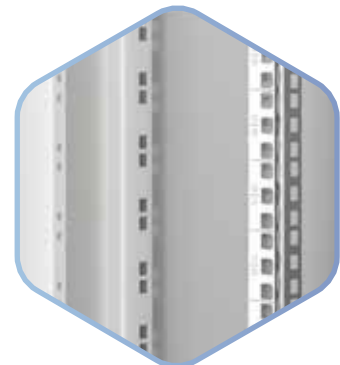

Lacing panel accessory installed



Dimensions

Width (mm)	600				800					
Height (RU)	37	42	45	47	37	42	45	47		
A - Height Outer Dimension (mm)	1750	1970	2105	2194	1750	1970	2105	2194		
B - Height Inner Door Opening (mm)	1648	1868	2003	2092	1648	1868	2003	2092		
C - Width Inner Door Opening (mm)	487				687					
Maximum recommended load (kg)	1800									
E - Depth (mm)	800				1000				1100	1200

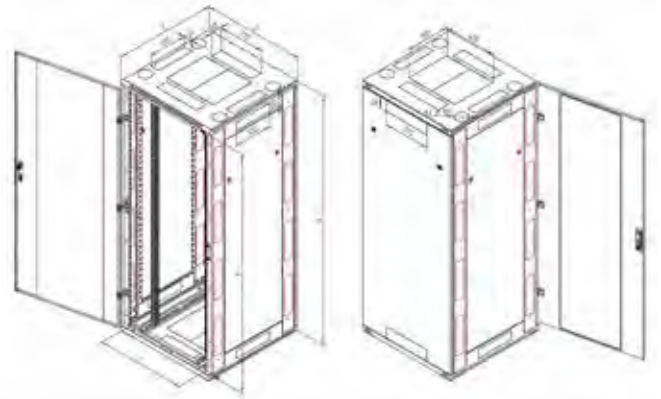

Ordering Information

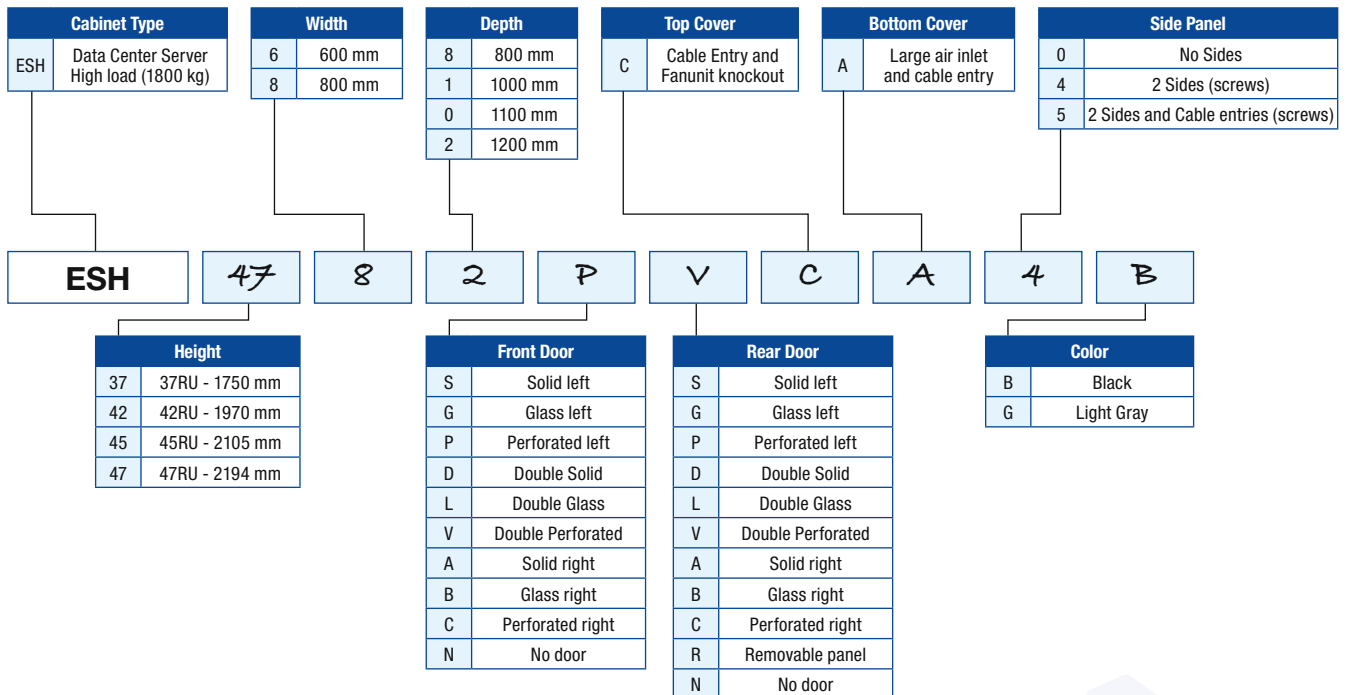

Notes:

- Side panels are fixed with screws
- Aisle containment preparation holes on both Front and Rear side of the cabinet
- Perforated doors have 80% openings by Mesh pattern

Part number example:

ESH4782PVCA4B Cabinet 47U 800 x 1200 mm, Perforated left door Front and Double perforated door Rear, Cable and fanunit cover, Bottom Airinlet, 2 Sides (screws), Black



X-Series DC Cabinets



XN-Series with 152 mm end-of-row extension



XN-Series
Frame only

XN – Networking and Switch Cabinet 1350 kg

Designed to handle dense patching fields while ensuring proper air flow

Features

- Modular cabinet designed for networking (cross connect) and switch hosting into Data Centers
- 30" (762 mm) wide cabinet, 42" or 48" (1067 or 1219 mm) deep with 42, 45 and 48 RU height options
- Unique open frame construction allows structural uprights to be positioned inside the frame, resulting in a corner post-free structure, enabling unobstructed access to front and rear vertical managers
- 6" (152 mm) cabinet extension can be mounted on each side of the 30" frame, resulting in a 42" frame for hosting of side-to-side venting switches
- Dual 270-degree swing prevents aisle blocking for end-of-row cabinets and optimizes access to right and left cable manager
- Doors feature 78% opened integrated hexagonal mesh for low air resistance and optimal cooling of the hosted gears (legacy doors available upon request)
- Integrated front and rear finger-style vertical managers
- Modular front-to-rear cable management options

- Vertical (Zero U) patch panel options, for integration of Belden pre-terminated copper and fiber connectivity products
- Front rail air seal and baffle for high level of separation between cold-supply air and hot-return air, ideal for high-density hosting
- Available in black and central office white

Switch Ready

- Switch-specific configuration includes air director for side-to-side venting switches (Ex: Cisco Catalyst 6509, Nexus 7018)

Containment Ready

- Fully compatible with passive or active (AEHC) chimney containment, up to 30 kW of hosting capacity

Power Ready

- XN cabinets are ready to host high-end power distribution units from Belden's line up of smart PDUs

30" Wide Cabinets

XN-Series Type	X3N42	X3N45	X3N48	X4N42	X4N45	X4N48
Dimensions: W x D x H (of Frame) – Inch (mm)	30" x 42" x 80.28" 762 x 1067 x 2040 mm	30" x 42" x 85.53" 762 x 1067 x 2173 mm	30" x 42" x 90.78" 762 x 1067 x 2307 mm	30" x 48" x 80.28" 762 x 1220 x 2040 mm	30" x 48" x 85.53" 762 x 1220 x 2173 mm	30" x 48" x 90.78" 762 x 1220 x 2307 mm
Available Mounting Rack Units (RU)	42	45	48	42	45	48
Front Frame Opening (W x H) – Inch (mm)	19.67" x 73.74" 500 x 874 mm	19.67" x 78.99" 500 x 2007 mm	19.67" x 84.24" 500 x 2141 mm	19.67" x 73.74" 500 x 1874 mm	19.67" x 78.99" 500 x 2007 mm	19.67" x 84.24" 500 x 2141 mm
Depth with Doors – Inch (mm)	42" (1067 mm)			48" (1219 mm)		
Usable Depth (1) – Inch (mm)	27.42" (697 mm)			33.42" (849 mm)		
Single Door Perforated Area	0.83 m ²	0.89 m ²	0.92 m ²	0.83 m ²	0.86 m ²	0.92 m ²

Note: (1) Distance from front-most mounting rail face to inside of rear frame.



XN Series Specifications

- Frame Construction: Welded 14 and 12 gauge
- Static Load Capacity: 1350 kg
- Capacity on Casters: 1020 kg with high-capacity casters
- Engineered and made in the USA



XN cabinet frames
30"W x 48"D x 45RU

6" between cabinet extension includes front and rear removable panels

6" end-of-row extension includes front and rear removable panels and side panel

78% open hex patterned door with patent-pending hinge design that offers superior security and a dual 270-degree swing

Optional air intake/exhaust duct for hosting of side-to-side venting switches

PDU mounting provision for easy integration of Belden high capacity smart PDUs

Corner-free frame allows for optimal access to integrated front and rear vertical managers

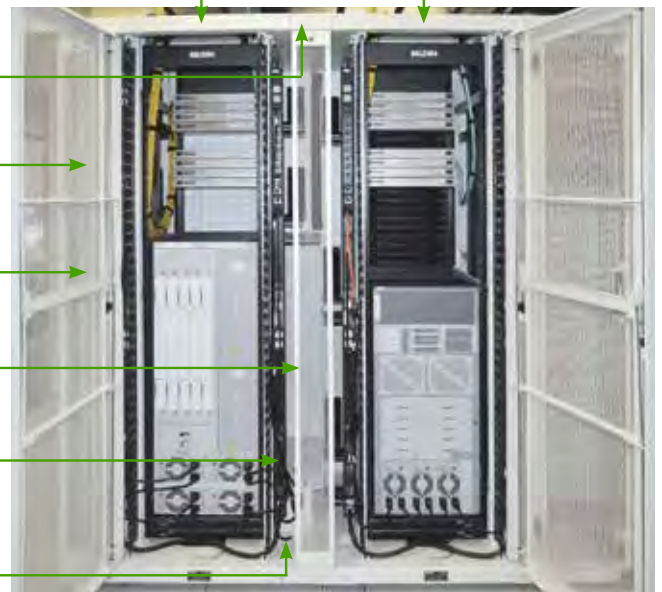

Ganged XN frames with end-of-row 6" extension and between cabinet 6" extension (rear view)

XN Series – Switch-Ready Configured Cabinets

Belden will configure cabinets to your exact requirements. The following allows seamless hosting of switches from CISCO's Catalyst and Nexus Series. Please contact your Belden sales representative to discuss your specific needs.

Item	Part Number	Frame Size			Color*	Rails	Top Panel	Doors		Lacing/PDU Panel	Air Director Duct	6" Frame Ext.
		Width	Depth	Height				Front	Rear			
1	X4N45-C6509101	30	48	45RU	Black	Square Rails	Brush Front/Rear	Perf.	Split Perf.	2 Rear	(1) 6509	None
2	X4N45-C6509102	30	48	45RU	Black	Square Rails	Brush + Chimney Ready	Perf.	Split Solid	2 Rear	(1) 6509	None
3	X4N45-C6509103	30	48	45RU	Black	Square Rails	Brush Front/Rear	Perf.	Split Perf.	2 Rear	(2) 6509	None
4	X4N45-C6509104	30	48	45RU	Black	Square Rails	Brush + Chimney Ready	Perf.	Split Solid	2 Rear	(2) 6509	None
5	X4N45-C7009101	42	48	45RU	Black	Square Rails	Brush Front/Rear	Perf.	Split Perf.	2 Rear	7009	Left/Right Side
6	X4N45-C7009102	42	48	45RU	Black	Square Rails	Brush + Chimney Ready	Perf.	Split Solid	2 Rear	7009	Left/Right Side
7	X4N45-C7010101	30	48	45RU	Black	Square Rails	Brush Front/Rear	Perf.	Split Perf.	2 Rear	None	None
8	X4N45-C7010102	30	48	45RU	Black	Square Rails	Brush + Chimney Ready	Perf.	Split Solid	2 Rear	None	None
9	X4N45-C7018101	42	48	45RU	Black	Square Rails	Brush Front/Rear	Perf.	Split Perf.	2 Rear	7018	Left/Right Side
10	X4N45-C7018102	42	48	45RU	Black	Square Rails	Brush + Chimney Ready	Perf.	Split Solid	2 Rear	7018	Left/Right Side

* For Central Office White color, replace 1 with 2 (ex: X4N45-C7018201).

Notes:

Switch-specific configuration includes all cabinet components needed to host given switch.

Configuration 3 and 4 allows for hosting of two CISCO Catalyst Series 6509 per cabinet.

Mounting Rails Construction: 11 gauge, marked RU, RU 1 is at bottom of cabinet.

Power Distribution Units (PDUs) are not included in above configurations; refer to PDUs Section of the catalog (pgs. 63–70) for options.

For "chimney-ready" configuration, refer to Containment Section of the catalog (pgs. 74-75) for chimney and accessories options.

Bottom panel with rear brushes is included.

Side panels (left and right) is included.

6" extension frame includes extension front and rear panels.

Solid rear panel for chimney ready cabinets.

X-Series DC Cabinets *(continued)*

Ordering Information for XN Series

Part number example:

X3N45132523121

30" x 42" x 45RU black frame with casters and levelers, 12-24 tapped rails, top panel with rear brush, perforated front door with dual lock handle, split perforated rear door with lock handle, 6" end-of-row extension left, side panel on right, brushed baffles, solid bottom.

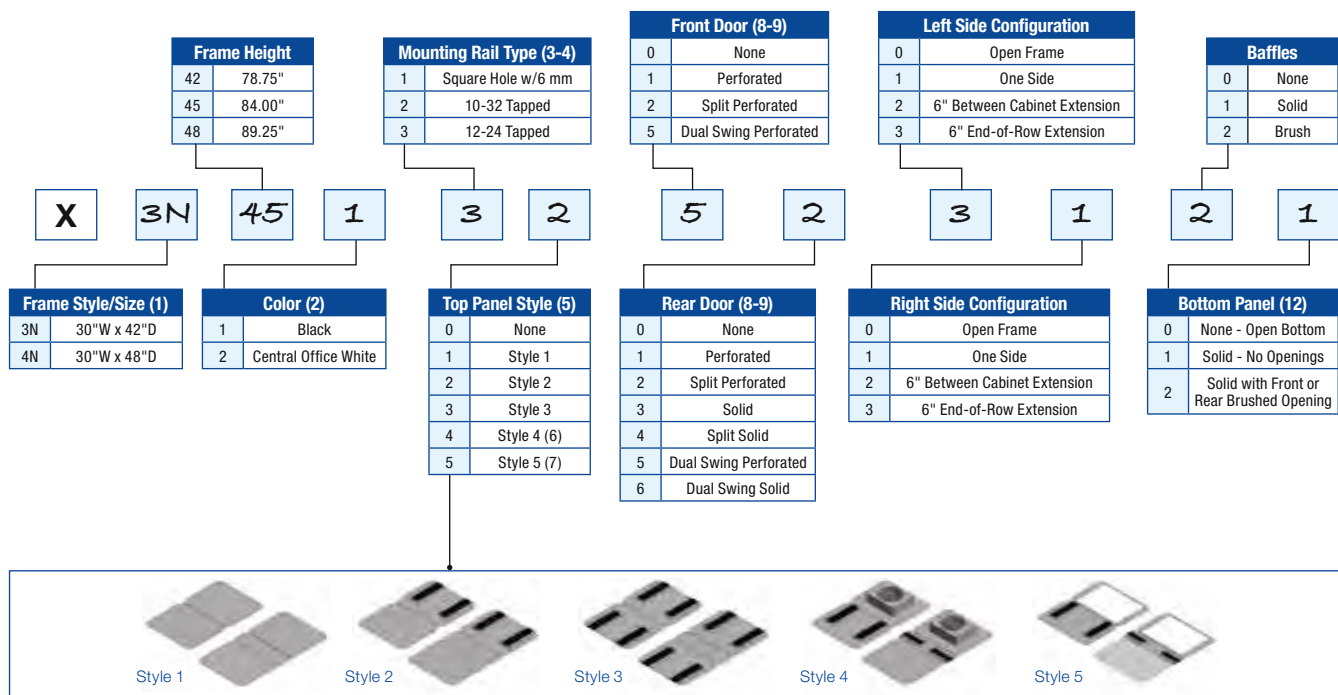

Notes:

- 1) Frame includes casters, levelers, ganging hardware, grounding studs in frame base front and rear.
- 2) Other colors and silk screening options available for volume orders.
- 3) Includes 2 pair of 19" mount EIA rails (marked RU, 1 at bottom) with mounting hardware (qty = 50). 6 mm hardware standard with square rails.

- 4) Default front rail position 3.81" from cabinet face and 30" between front and rear rails.
- 5) Custom top panel available for volume orders.
- 6) Fan top panel includes 10" dia. 550 CFM fan (120 V).
- 7) Style 5 top panel to accept passive or active containment chimney.
- 8) Front and rear doors include latching handle with key lock and bonding strap.

- 9) Single door swings left to right and is field reversible.
- 10) Side panel includes two half-height panels with key lock and bounding strap. Panel does not add width to cabinet.
- 11) Side panels with brushes or perforated rear available from component selection.
- 12) Bottom brush panel can be rotated 180° for choice of front or rear brush entry.



XN Series – Individual Components Ordering Options

Door with Latch Lock Handle

When switching doors out, door adapter comes with door.

XN		30		D	
Frame Height		Door Style		Color	
42	42RU	CP	Curved Perforated	01	Black
45	45RU	FP	Flat Perforated	02	CO White
48	48RU	SP	Split Perforated		
		S	Solid		
		SS	Split Solid		
		PDS	Perforated Dual Swing		
		SD	Solid Dual Swing		

Side Extension Doors

Side Extension Panel with lock. Includes one panel (can be use front or rear).

XN		SXF			
Frame Height		Door Style		Color	
42	42RU	SD	Solid Door	01	Black
45	45RU	PD	Perforated Door	02	CO White
48	48RU				

Top Panel Sections

Small section 5 and 6 only applicable to 48" deep cabinets. No panel required for chimney containment on cabinet.

X24TP			
Top Panel Section		Color	
1	Solid	01	Black
2	With Brushed Openings	02	CO White
3	With 10" dia. 550 CFM Fan		
5	Small Section, Solid		
6	Small Section, w/Brushed Openings		
7	With Large Brushed Openings		

Cabinet Frame

No rails, levelers, and casters.

X		N			
Frame Depth		Frame Height		Color	
3	42"	42	42RU	01	Black
4	48"	45	45RU	02	CO White
		48	48RU		

EIA Mounting Rails

Includes two pair of rails and mounting hardware (50). Default hardware for cage nut style rails is M6.

XN		30RLS	
Frame Height		Mounting Rail Type	
42	42RU	CN6	6 mm Cage Nut
45	45RU	1032	10-32 Tap
48	48RU	1224	12-24 Tap

Cabinet Bottom Cover

When panel with brush is selected, will ship brush in cabinet rear.

XN24		BC			
Frame Depth		Panel Type		Color	
42	42"	S	Solid	01	Black
48	48"	WB	w/Brush	02	CO White

Side and Extension Panel

Side panel mounted (default position) on right side facing cabinet front. Panel # includes bottom and top panels, mullion.

XN			SP				
Frame Height		Frame Depth		Side Panel Kit (2)		Color	
42	42RU	42	42"	S	w/Lock	01	Black
45	45RU	48	48"	PP	w/Rear Perforation w/Lock	02	CO White
48	48RU			PB	w/Front and Rear Brush w/Lock		

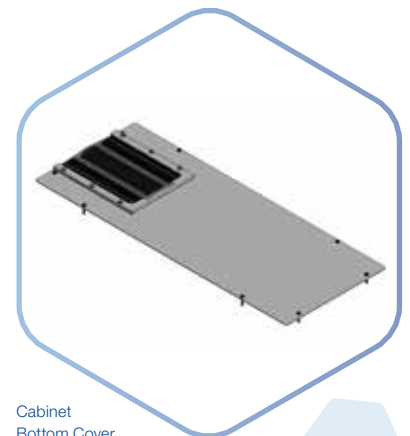

Cabinet Bottom Cover

X-Series DC Cabinets *(continued)*

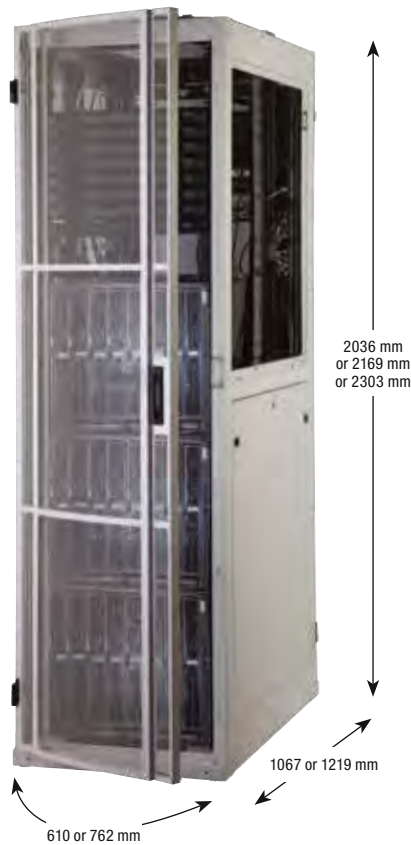

XHS – Server Cabinet 1350 kg

Supports high load capacities and proper air flow management

Construction

- Welded 14-gauge frame and 11-gauge mounting rails support a static load of 1350 kg (1020 kg on high capacity casters) to host a full rack of blade servers
- Cabinets frames are fixtured and robotically welded for optimal squareness
- Rail seal and adaptive containment eliminate hot spots and provide energy efficiency, monitoring and alarming
- Designed and tested for use with Belden Fiber and Copper Networking solutions

Ease of Installation

- Modular design with options on doors, side panels, air flow management, cable management and PDU monitoring, offering ease of installation plus scalability
- Doors can be easily removed and oriented for left or right swing to suit application needs
- Highly integrated and shipped fully assembled with power, air flow, connectivity and cable management
- Optimal physical density and networking bandwidth for ease of moves, adds and changes

Cable and Air-Flow Management

- XHS series cabinets are available in 762 mm and 1016 mm wide version for optimal servers and switch hosting. Intake and exhaust duct options allowing side to side gears hosting
- Integrated punched hex pattern is 78% open for low-resistance airflow through doors (legacy doors available upon request)
- Front rail seals enable physical separation of supply and return air for optimized hot/cold aisle and containment deployment
- 1067 mm and 1219 mm deep versions easily host deep equipment chassis with rear space for power and cable management
- Available in 42, 45 and 48RU for a variety of hosting requirements

Containment and Power Distribution

- Complete line up of IP-based power distribution units (PDUs) with available monitoring, alarming and receptacle-level switching
- Enables up to 30kW per cabinet with Belden's innovative passive and adaptive (AEHC) chimneybased containment systems

Aesthetics

- Designed and manufactured in the USA and fully customizable to meet specific equipment hosting challenges
- Available in Central Office white for improved internal visibility and reduced lighting needs
- 270-degree door swing means doors won't block aisles on end-of-row cabinets



XH1S451100000
(45RU H x 762 mm W
x 1067 mm D)



X2S451121110
XHS Cabinet with
optional Zeru U patch panel
(762 mm W x 1219 mm D x 45RU), rear view



XHS Series Specifications

- Perforated Door Mesh Opening: 78%
- Patented Hinge Design: Secure, Dual 270-degree Swing
- UL 2416 Listed
- Frame Construction: Welded 14 gauge
- Fixtured and robotically welded for squareness
- Mounting Rails Construction: 11 gauge, marked RU, RU 1 is at bottom of cabinet
- Static Load Capacity: 1350 kg
- Capacity on Casters: 263 kg on regular capacity casters, 1020 kg with high-capacity casters
- EIA 310 Compliant: 19" mounting
- Vertical Cable Management Options (See pages 57-58 for X Series Cabinet Accessories)
- Horizontal Cable Management Options (See page 46 for Accessories)
- Zero U – Vertical Patch Panel (See page 58)
- Tool Less PDUs Mounting Options (See page 57)
- Heat Containment Options (See pages 74-75)
- Engineered and made in the USA

30" Wide Cabinets (762 mm)

XHS Series Type	XH1S	XH2S	XH1S	XH2S	XH1S	XH2S
Available Mounting Rack Units (RU)	42RU		45RU		48RU	
Dimensions: W x D x H (of frame)	762 x 1067 x 2003 mm	762 x 1219 x 2003 mm	762 x 1067 x 2134 mm	762 x 1219 x 2134 mm	762 x 1067 x 2267 mm	762 x 1219 x 2267 mm
Front Frame Opening (W x H)	692 x 1876 mm		692 x 2009 mm		692 x 2142 mm	
Depth w/ two Perf. Doors (1)	1162 mm	1314 mm	1162 mm	1314 mm	1162 mm	1314 mm
Usable Depth (2)	1035 mm	1187 mm	1035 mm	1187 mm	1035 mm	1187 mm
Single Door Perf Area (3)	1.16 m ²		1.25 m ²		1.33 m ²	

Note: (1) Standard Cabinet w/ curved perf front door and split perf rear door (2) Distance from front-most mounting rail face to inside of rear frame (3) Based on curved perf door

40" Wide Cabinets (1016 mm)

XHS Series Type	XH3S	XH4S	XH3S	XH4S	XH3S	XH4S
Available Mounting Rack Units (RU)	42RU		45RU		48RU	
Dimensions: W x D x H (of frame)	1016 x 1067 x 2003 mm	1016 x 1219 x 2003 mm	1016 x 1067 x 2134 mm	1016 x 1219 x 2134 mm	1016 x 1067 x 2267 mm	1016 x 1219 x 2267 mm
Front Frame Opening (W x H)	946 x 1876 mm		946 x 2009 mm		946 x 2142 mm	
Depth w/ two Perf. Doors (1)	1162 mm	1314 mm	1162 mm	1314 mm	1162 mm	1314 mm
Usable Depth (2)	1035 mm	1187 mm	1035 mm	1187 mm	1035 mm	1187 mm
Single Door Perf Area (3)	1.71 m ²		1.79 m ²		1.88 m ²	

Note: (1) Standard Cabinet w/ curved perf front door and split perf rear door (2) Distance from front-most mounting rail face to inside of rear frame (3) Based on curved perf door

XHS Series – Configured Cabinets

Belden will configure cabinets to your exact requirements. The following are commonly requested configured cabinets. Please contact your sales representative to discuss your specific needs.

Item	Part Number	Frame Size			Color	Rails	Top Panel	Doors		Side Panel	Bottom Panel	Lacing/PDU Panel	Vertical Mngr.	
		Width	Depth	Height				Front	Rear				Fingers on Rail	Box Style Mngr.
1	XH1S45-C1000	30" (762 mm)	42" (1067 mm)	45RU	Black	Square Rails	Brush Front/Rear	Perf.	Split Perf.	1 Solid	Open	2 x 3" + 2 x 7" Rear	No	No
2	XH2S45-C1000	30" (762 mm)	48" (1219 mm)	45RU	Black	Square Rails	Brush Front/Rear	Perf.	Split Perf.	1 Solid	Open	2 x 7" Rear	No	Rear Rails
3	XH2S45-C1001	30" (762 mm)	48" (1219 mm)	45RU	Black	Square Rails	Brush+Chimney Ready	Perf.	Split Solid	1 Solid	w/brush	2 x 7" Rear	No	Rear Rails
4	XH1S45-C2000	30" (762 mm)	42" (1067 mm)	45RU	CO White	Square Rails	Brush Front/Rear	Perf.	Split Perf.	1 Solid	Open	2 x 3" + 2 x 7" Rear	No	No
5	XH2S45-C2000	30" (762 mm)	48" (1219 mm)	45RU	CO White	Square Rails	Brush Front/Rear	Perf.	Split Perf.	1 Solid	Open	2 x 7" Rear	No	Rear Rails
6	XH2S45-C2001	30" (762 mm)	48" (1219 mm)	45RU	CO White	Square Rails	Brush+Chimney Ready	Perf.	Split Solid	1 Solid	w/brush	2 x 7" Rear	No	Rear Rails

X-Series DC Cabinets *(continued)*

Ordering Information for XHS Series

Part number example:

XH1S451311221

30" x 42" x 45RU, black frame with casters and levelers, 12-24 tapped rails, solid top, curved perforated front door with lock handle, split perforated rear door with locking handle, both side panels with locks, solid bottom.

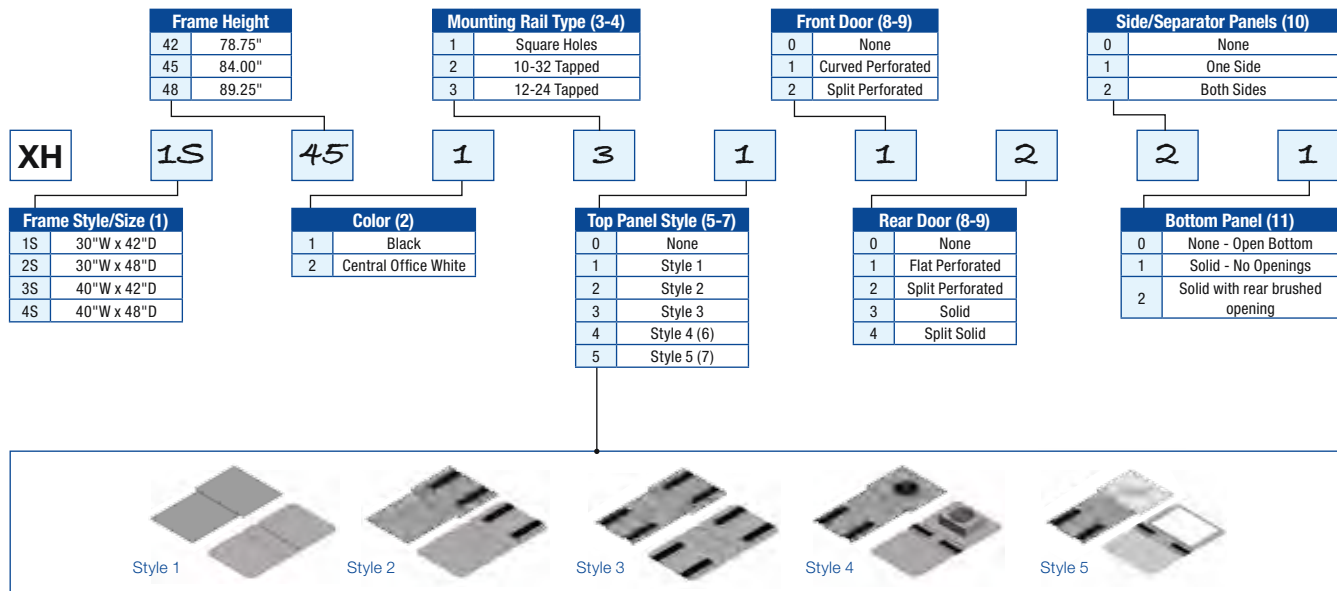

Notes:

- 1) Frame includes levelers, ganging hardware, grounding studs in frame base front and rear.
- 2) Other colors and silk screening options available for volume orders.
- 3) Includes 2 pair of 19" mount EIA rails (marked RU, 1 at bottom) with mounting hardware (qty = 50). 6 mm hardware standard with square rails.
- 4) Default front rail position 3" from cabinet face and 30" between front and rear rails.
- 5) Custom top panel available for volume orders.
- 6) Fan top panel included, 10" dia., 550 CFM fan (120V).
- 7) Style 5 top ready to accept passive or active containment chimney.
- 8) Front and rear doors include latching handle with key lock and bonding strap. Refer to Cabinet Access System Section for other access options.
- 9) Single door swings left to right and is field reversible. Refer to Cabinet Access System Section for other access options.

- 10) Side panel includes embossed key lock and bonding strap. Side panel made of a lower and upper panel. Side panels are flush, do not add width to cabinet and can be used as separator panel between cabinets.
- 11) Bottom brush panel can be rotated 180° for choice of front or rear brush entry.





XHS Series – Individual Components Ordering Options

Top Panel Sections

HS						TP					
Frame Width		Frame Depth		Top Panel Section				Color			
30	30"	42	42"	1	Black			01	Black		
40	40"	48	48"	2	Solid with rear brush			02	CO White		
				3	Solid with front and rear brush						
				4	With 25 mm dia. 550 CFM Fan						
				5	With Chimney Opening						

Side or Separator Panel

Side panel includes embossed key lock and bonding strap. Side panel made of a lower and upper panel. Side panel are flush, do not add width to cabinet and can be used as separator panel between cabinets.

H						SP			
Frame Height		Frame Depth		Color					
42	42RU	42	42"	01	Black				
45	45RU	48	48"	02	CO White				
48	48RU								

EIA Mounting Rails

Includes two pair of rails and mounting hardware (50). Default hardware for cage nut style rails is M6.

HS						RLS			
Frame Height		Frame Width		Mounting Rail Type					
42	42RU	30	30"	CN6	EIA Rail 6 mm Cage Nut				
45	45RU	40	40"	1032	EIA Rail 10-32 tap				
48	48RU			1224	EIA Rail 12-24 tap				

Door with Latch Handle

HS								D			
Frame Height		Frame Width		Door Style				Color			
42	42RU	30	30"	CP	Curved Perforated			01	Black		
45	45RU	40	40"	FP	Flat Perforated			02	CO White		
48	48RU			SP	Split Perforated						
				S	Solid						
				SS	Split Solid						

Cabinet Frame

Do not include rails, levelers and casters.

HS							
Frame Style/Size		Frame Height		Color			
1S	24"W x 42"D	42	42RU	01	Black		
2S	24"W x 48"D	45	45RU	02	CO White		
3S	30"W x 42"D	48	48RU				
4S	30"W x 48"D						

Cabinet Bottom Cover

When panel with brush is selected, will ship with brush in cabinet rear.

HS						BC				
Frame Width		Frame Depth		Cable Access				Color		
30	30"	42	42"	S	Solid			01	Black	
40	40"	48	48"	WB	w/Brush			02	CO White	

Bottom Seal Skirt

Front and side skirt allow sealing below cabinets when on levelers.

H						S			
Skirt Width		Skirt Style		Color					
30	30"	B	Bottom Front		01	Black			
40	40"	S	Bottom Side		02	CO White			
42	42"								
48	48"								

BELDEN
SENDING ALL THE RIGHT SIGNALS

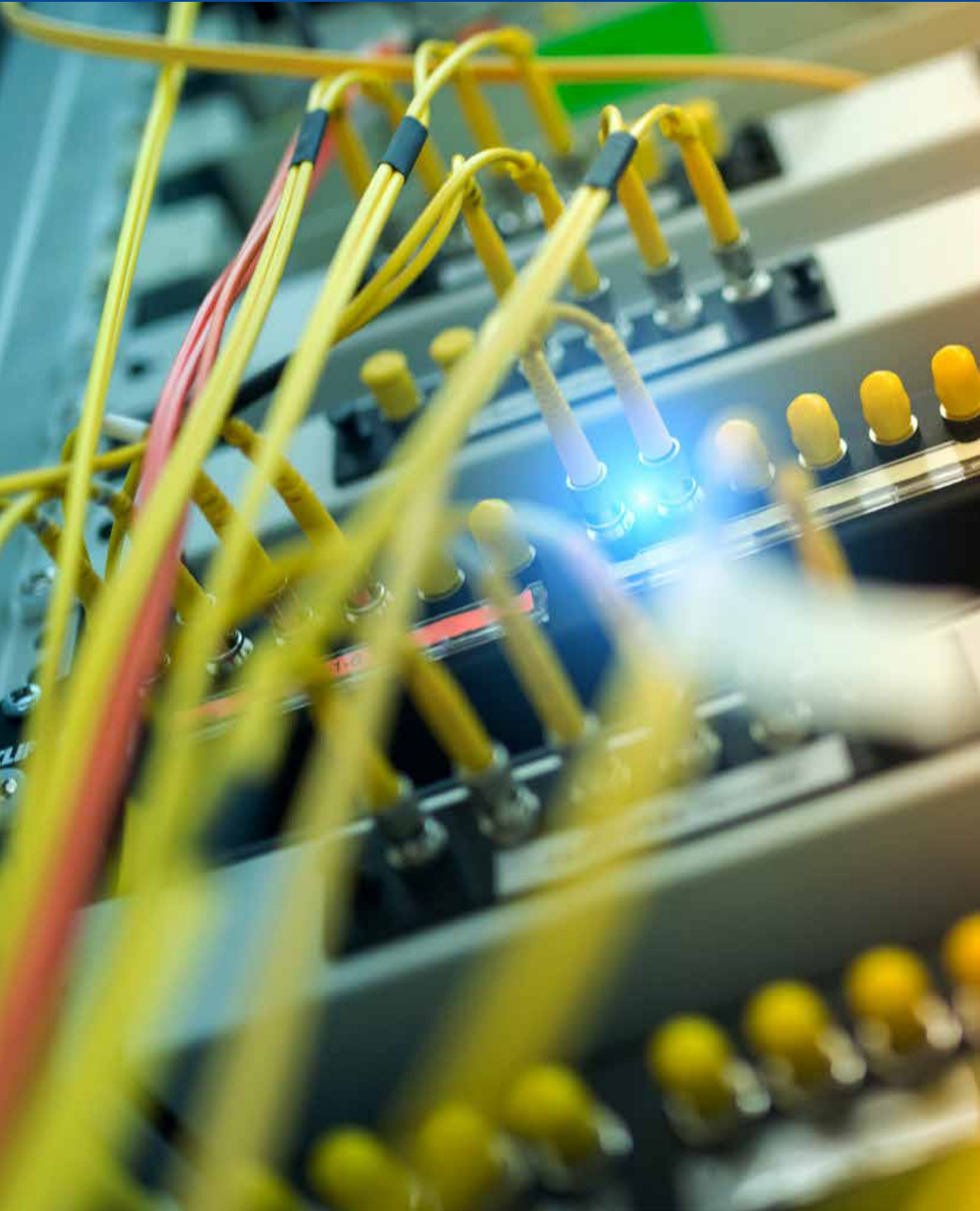



Section Three

Components and Accessories

Section THREE – Components and Accessories

19" Accessories	45-47
Horizontal Cable Managers	46
Filler Panels	47
Shelfs	47
E-Series Cabinet Accessories	48-53
Vertical Cable Manager Finger Style	48
VCM Lacing Panel and Toolless PDU holder	49
HCM Front to Rear	49
Separation Frame	50
Stability Frame incl. Cable Management	50
Fan Units with Thermostat	51
Bases	51
Grounding Bar Vertical	52
Other Accessories for E-Series	53
X-Series Cabinet Accessories	54-59
XN Cabinets	54-55
XHS Cabinets	56-59



19" Accessories

Horizontal Cable Managers

Application

Horizontal managers allow routing of copper and fiber cables/patch cords in racks and cabinets while helping to maintain proper bend radius and organize array for ease of moves, adds and changes.

Features include:

- 1RU to 4RU height
- 19" mount includes mounting hardware
- Compatible with racks and cabinets
- Selection of ring, finger and cable tie bar style horizontal managers
- Standard color is black (other colors available on volume orders)



Horizontal Cable Managers
Top: EDAH1202 (1U plastic)
Middle: EDAH1102 (1U plastic)
Bottom: EDAH2102 (1U metal)

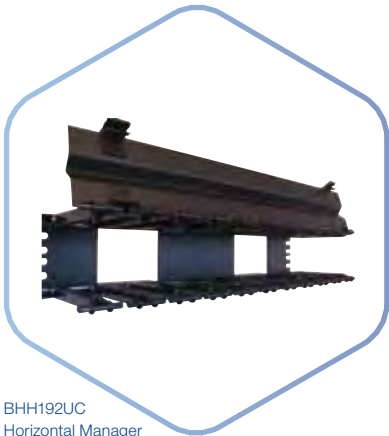

BHH192UC
Horizontal Manager
1U finger style including cover

Description	RU	Manager Cross Section H x D	Part Number
Horizontal Cable Managers			
Horizontal Cable Manager, Plastic, with Fingers and Cover	1RU	42 x 50 mm	EDAH1102
Horizontal Cable Manager, Plastic, with Fingers and Cover	2RU	75 x 50 mm	EDAH1202
Horizontal Cable Manager, Metal, with Rings and Cable Guiding, Black	1RU	42 x 50 mm	EDAH2102
Horizontal Cable Manager, Metal, with Rings and Cable Guiding, Light Gray	1RU	42 x 50mm	EDAH2101
Horizontal Manager with Molded Fingers and Hinging Cover	1RU	45 x 145 mm	BHH191UC
Horizontal Manager with Molded Fingers and Hinging Cover	2RU	90 x 145 mm	BHH192UC
Horizontal Manager with Molded Fingers and Hinging Cover	3RU	135 x 145 mm	BHH193UC
Horizontal Manager with Molded Fingers and Hinging Cover	4RU	180 x 145 mm	BHH194UC



Filler Panels

Application

- Filler Panels allow blocking of unused rack units (RU) for optimized airflow and separation between cold supply air and hot return air
- Best practices in Data Centers includes blanking of all unused rack units (RU)
- Filler Panels are compatible with 19" mount racks and cabinets

Description	Color	Part Number
Filler Panels		
Metal		
1RU Metal Filler Solid incl. cage nut	Light Gray / Black	EDAP1011/2
2RU Metal Filler Solid incl. cage nut	Light Gray / Black	EDAP1021/2
3RU Metal Filler Solid incl. cage nut	Light Gray / Black	EDAP1031/2
4RU Metal Filler Solid incl. cage nut	Light Gray / Black	EDAP1041/2
1RU Metal Filler With Brush incl. cage nuts	Light Gray / Black	EDAP3311/2
Plastic Tool-Less		
1RU Solid Filler Panel (fits 10-32, 12-24 and square holes rails)	Black/CO White	9910-0100PL-01/-02
2RU Solid Filler Panel (fits 10-32, 12-24 and square holes rails)	Black/CO White	9911-0200PL-01/-02

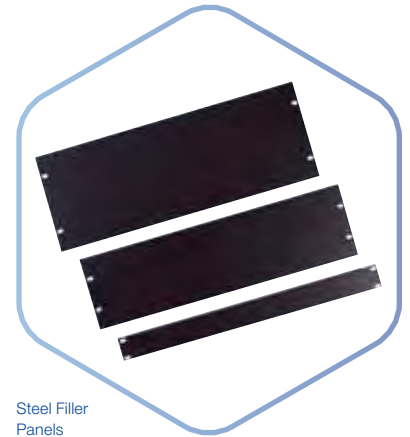

Steel Filler Panels

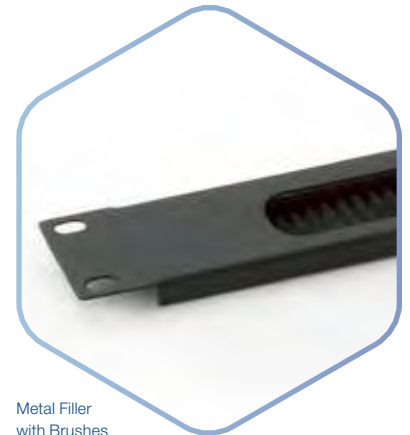

Metal Filler with Brushes EDAP3312

Shelves

Regular Shelves and Heavy Duty 19" Shelf for supporting equipment up to 150 kg load. Available in several depths and is mounted on each corner to the frame for maximum stability. The depth of mounting is adjustable.

Ordering Information

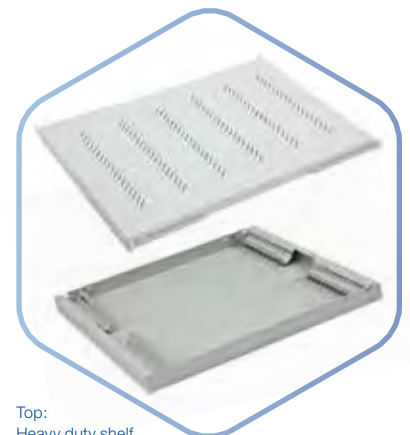
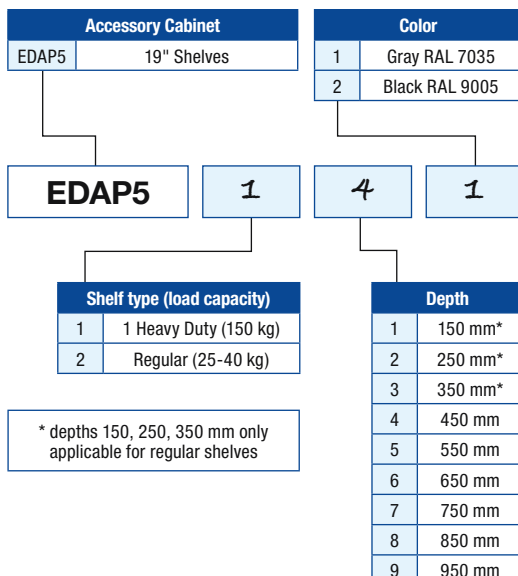

Top: Heavy duty shelf
Bottom: Regular shelf



E-Series Accessories

E-Series Cabinet specific Accessories

Dependent on the Cabinet series, or type of cabinet, there are cabinet specific accessories, especially designed for the frame or application.

Vertical Cable Manager Finger Style

Vertical Cable Management (VCM) available for 600 and 800 mm wide E-Series Free Standing Cabinets. Full length (e.g. 42U) to accommodate entire cabinet. The Installation is realized to the vertical rail by screws (included in standard package). An optional cover (EDAV3*) secures cables when the EDAV2* Double Finger style VCM is chosen.

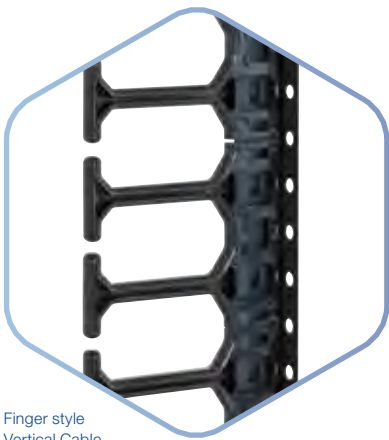

Finger style
Vertical Cable
Manager

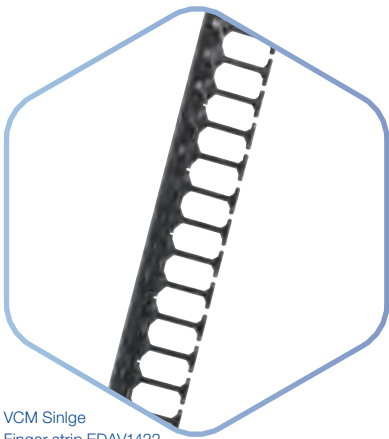

VCM Single
Finger strip EDAV1422

Ordering Information

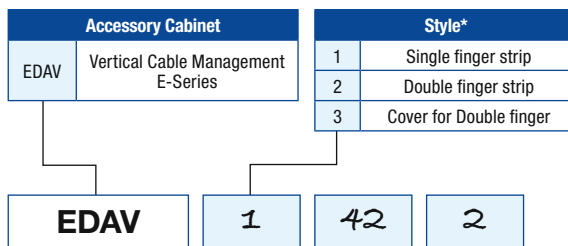

* 600 mm wide cabinets only accept Style 1 – Single finger strip

Height	
10	10RU
15	15RU
18	18RU
22	22RU
27	27RU
32	32RU
37	37RU
42	42RU
45	45RU
47	47RU



VCM Double
Finger strip EDAV2102



EDAV3* Cover
for VCM



VCM Lacing panel and Toolless PDU holder

Vertical Cable Management (VCM) Lacing panel can be installed in the corner of the frame for EDC, ESN and ESH cabinet types. By use of a uniform pattern, the vertical panel can be used for tool-less mount Belden PDUs, Lacing of cable bundles, Attachment of additional cage nuts, Attachment of slack management spools.



VCM Installed

Ordering Information

Accessory Cabinet		Style																	
EDAV	Vertical Cable Management E-Series	5	Lacing Panel*																
EDAV	5	42	0																
* Applicable for EDC, ESN and ESH Cabinets		<table border="1"> <thead> <tr> <th colspan="2">Height</th> </tr> </thead> <tbody> <tr><td>22</td><td>22RU</td></tr> <tr><td>27</td><td>27RU</td></tr> <tr><td>32</td><td>32RU</td></tr> <tr><td>37</td><td>37RU</td></tr> <tr><td>42</td><td>42RU</td></tr> <tr><td>45</td><td>45RU</td></tr> <tr><td>47</td><td>47RU</td></tr> </tbody> </table>		Height		22	22RU	27	27RU	32	32RU	37	37RU	42	42RU	45	45RU	47	47RU
Height																			
22	22RU																		
27	27RU																		
32	32RU																		
37	37RU																		
42	42RU																		
45	45RU																		
47	47RU																		

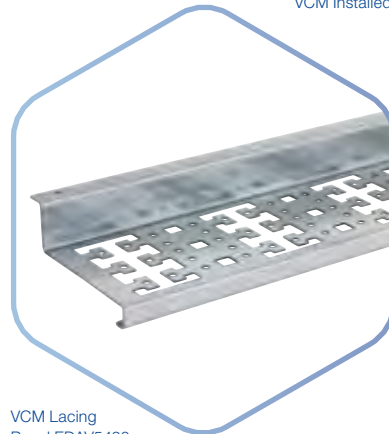

VCM Lacing Panel EDAV5420

HCM Front to Rear

Horizontal Cable Management (HCM) Rail from Front to Rear of the cabinet is available for EDC, ESN and ESH cabinets in various depths and standard colors.

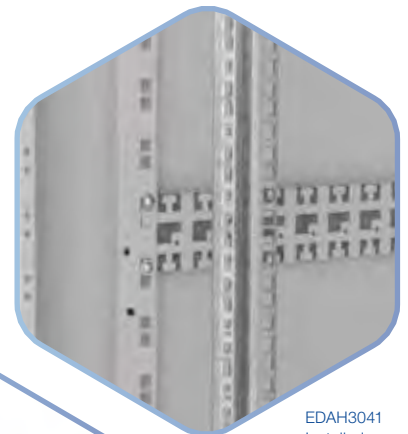

EDAH3041 Installed

Ordering Information

Accessory Cabinet		Color															
EDAH	Horizontal Cable Management E-Series	1	Gray RAL 7035														
		2	Black RAL 9005														
EDAH	30	4	1														
* Applicable for EDC, ESN and ESH Cabinets		<table border="1"> <thead> <tr> <th colspan="2">Depth</th> </tr> </thead> <tbody> <tr><td>6</td><td>600 mm</td></tr> <tr><td>8</td><td>800 mm</td></tr> <tr><td>9</td><td>900 mm</td></tr> <tr><td>1</td><td>1000 mm</td></tr> <tr><td>0</td><td>1100 mm</td></tr> <tr><td>2</td><td>1200 mm</td></tr> </tbody> </table>		Depth		6	600 mm	8	800 mm	9	900 mm	1	1000 mm	0	1100 mm	2	1200 mm
Depth																	
6	600 mm																
8	800 mm																
9	900 mm																
1	1000 mm																
0	1100 mm																
2	1200 mm																
		<table border="1"> <thead> <tr> <th colspan="2">Type</th> </tr> </thead> <tbody> <tr> <td>30</td> <td>Front to Rear</td> </tr> </tbody> </table>		Type		30	Front to Rear										
Type																	
30	Front to Rear																



Horizontal Cable Manager front to rear

E-Series Accessories *(continued)*



Separation frame available for ESN and ESH Cabinets

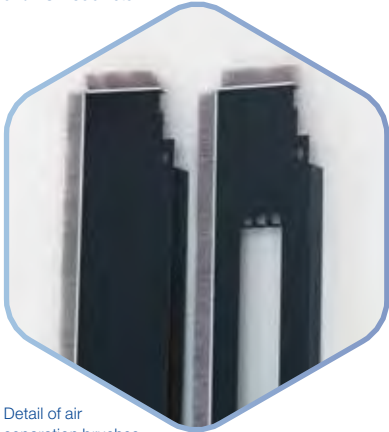

Detail of air separation brushes

Separation frame

Especially designed for air controlled environments such as Datacenters, the separation frame for E-Series ensures efficient air management. Mounted between the rails and the frame of the cabinet and sealed off by brushes, it separated the hot from the cold air. The Zero U Mounting version provides up to six additional 19" Rack unit positions in the cabinet installation and allows routing of cabling through the separation frame to the rear of the cabinet.

Ordering Information

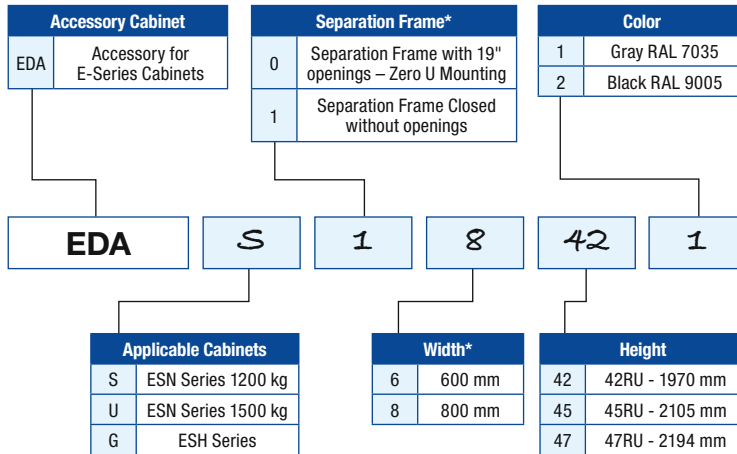

* Zero U mounting only possible with 800 mm wide cabinets



EDASC* stability frame and cable management

Stability Frame incl. Cable Management

This kit is for 800 mm wide ESN cabinets to provide extra stability when standing alone and provides cable management. The stability frame is not required when the cabinet is bayed together with one or more other cabinets. The frame also provides cable management.

Ordering Information

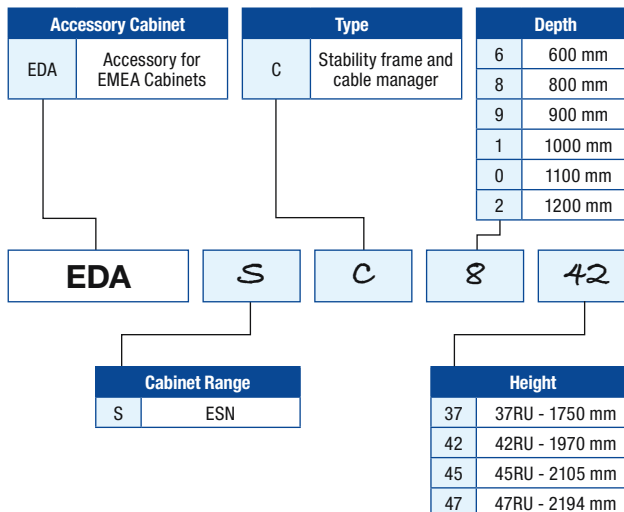



Fan units with Thermostat

Fan units especially made to fit all Belden E-Series Free standing cabinets, where they can be installed in the top cover from outside of the enclosure. The fan is kept in place using four latches and by gluing tape for sealing.

- Temperature adjustment by bimetallic thermostat
- Three units available with 2, 4 or 6 fans
- Airflow of one fan is 160 m3/hr
- Option to order without power cord when the electrical power grid requires different plug type



Fanunit with 4 fans and thermostat

Ordering Information

Accessory Cabinet		Color	
EDAF1	Fan units E-Series	1	Gray RAL 7035
		2	Black RAL 9005

EDAF1	0	4	1
--------------	----------	----------	----------

Power cord for C13		# fans	
0	CEE 7/7 power cord	2	2 fans
1	Without power cord	4	4 fans
		6	6 fans

Bases

The base is constructed out of two side profiles which correspond to the depth and width of all E-Series cabinet. Height of the bases is 120 mm and can support maximum capacity of 1500 kg.

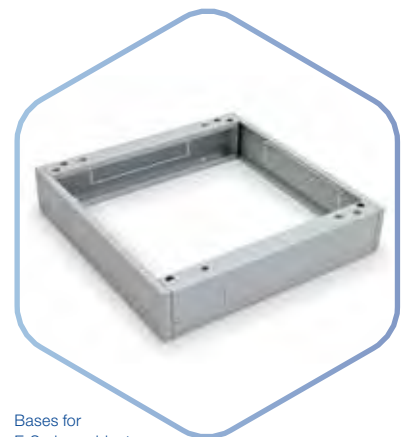

Bases for E-Series cabinets

Ordering Information

Accessory Cabinet		Color	
EDAB2	Bases 1500 kg E-Series	1	Gray RAL 7035
		2	Black RAL 9005

EDAB2	8	1	1
--------------	----------	----------	----------

Width		Depth	
6	600 mm	6	600 mm
8	800 mm	8	800 mm
		1	1000 mm
		2	1200 mm



Bases package detail



E-Series Accessories *(continued)*



Grounding clamp

Grounding Bar

Solid copper rod and clamps for Grounding equipment. Available for 42, 45 and 47U vertical mounting and 19" horizontal mounting (installation screws included).

Ordering Information

Accessory Cabinet	
EDAC4	Grounding Component

EDAC4	11	0
--------------	-----------	----------

Depth	
11	Grounding rail 19" x 5 x 20 mm
12	Grounding rail 42RU x 5 x 20 mm
15	Grounding rail 45RU x 5 x 20 mm
17	Grounding rail 47RU x 5 x 20 mm
20	Grounding clamp



Copper rod 5 x 20 mm



Other Accessories for E-Series

Baying kit

Baying kits are used for connecting Enclosures together in a row.



Baying kit for E-Series

PDU mounting bracket

Set of 2 brackets made to mount Belden PDU's in free standing cabinets (EDC, ESN and ESH series). The brackets are being delivered with bolts to install them in the cabinet. The PDU can be mounted to the brackets with bolts and cage nuts.



PDU Holder 1U



PDU Holder 2U

Casters

Casters are installed on the bottom plate of the Cabinets. Maximum load capacity is 800 kg. By installing the casters, the height of the cabinet increases by 108 mm.



EDAB4120 – Casters for E-Series Cabinets

Description	Part Number
Other Cabinet specific Accessories	
PDU Holder	
PDU holder 1U for Cabinet ESN ESH in frame Pair	EDAC8510
PDU holder 2U for Cabinet ESN ESH in frame Pair	EDAC8520
Baying Kits	
Baying kit with sealing tape	EDAC2270
Baying kit with/o sealing tape	EDAC2280
Casters	
Casters max load 800 kg (4pcs)	EDAB4120
Cage Nut set (4pcs)	EDAC3100
Cage Nut set (20pcs)	EDAC3200
Cage Nut set (50pcs)	EDAC3300
Cable Ties	
Velcro Cable Ties, 25 per Roll, 200 mm long	AX100783
Velcro Cable Ties, 25 per Roll, 300 mm long	AX100784
12" Fiber Optic Cable Manager 1	AX102516
24" Fiber Optic Cable Manager 1	AX102517
Fiber Slack Management Spools 150 mm deep (includes 2 spools)	BHSP020
Fiber Slack Management Spools 50 mm deep for lacing panels (includes 2 spools)	BHSP030



AX102516
Cable Slack
Management Ring – 12" diameter

X-Series Accessories

XN-Series

Accessories explicitly used on XN Cabinets

Horizontal Managers

Horizontal manager waterfall attaches to horizontal manager bar.

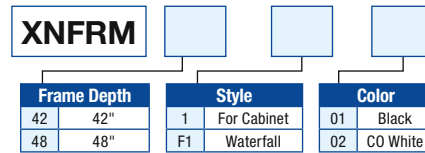

Horizontal Trough Managers

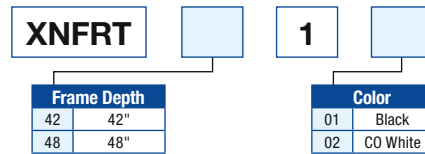

Side Extension Kits with Side Panel

Allows for 6" extension to cabinet, can be used on both sides. Front and rear panel not included.

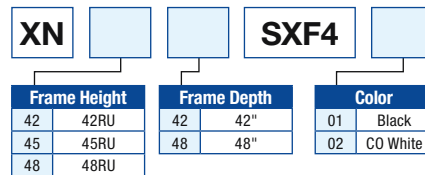

Seal Kit

Seal kit bolt between the front of two 30" frames to allow front-to-rear air separation.

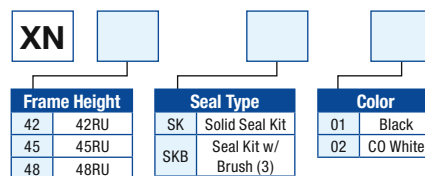

Vertical Lacing Panel

Needs (3) horizontal manager bars for mounting.

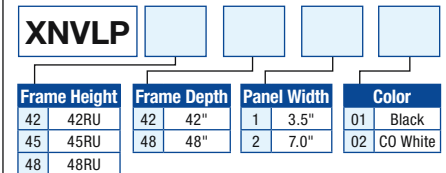

Vertical Ground Bars

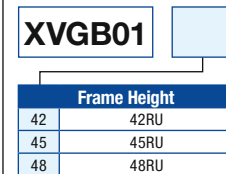

Between Cabinets Extension Kits

6" extension kits for bolting between two cabinets. Front and rear panel not included.

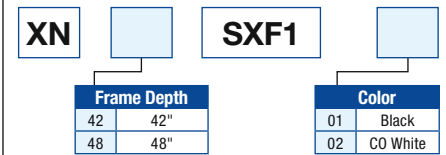

Vertical Door Kit

Mounts between two existing frames with fingers on the post.

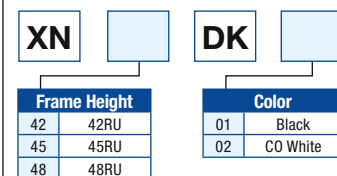



Description	Part Number
Other Accessories	
Front Air Baffle	
Air Baffle 45RU X 2.0" Wide, Single, Black	XN4530ADS0101
Air Baffle 45RU X 6.25" Wide, Single, Black	XN4530ADS0301
Air Baffle with Brush (3) 45RU X 6.25" Wide, Single, Black	XN4530ADS0401
Air Baffle 45RU X 2.0" Wide, Single, CO White	XN4530ADS0102
Air Baffle 45RU X 6.25" Wide, Single, CO White	XN4530ADS0302
Air Baffle with Brush (3) 45RU X 6.25" Wide, Single, CO White	XN4530ADS0402
Brush for Front Air Baffle	
Brush Kit 5.5"W x 11.5"H (1 per) for Front Air Baffle, Black Frame	XNSKB01
Brush Kit 5.5"W x 11.5"H (1 per) for Front Air Baffle, CO White Frame	XNSKB02
Finger Managers	
Finger Manager Kit Front Face Mount for 1 Rail, 42RU	XNFS42
Finger Manager Kit Front Face Mount for 1 Rail, 45RU	XNFS45
Finger Manager Kit Front Face Mount for 1 Rail, 48RU	XNFS48
Power Distribution Mounting Brackets	
PDU Mounting Bracket Double, Post Mounting 2 PDU Side-by-Side Facing into Cabinet	XNPM01
PDU Mounting Bracket Single, Rear Facing Pair	XNPM02
PDU Mounting Bracket Rear Facing Pair Between Frames	XNPM03
PDU Mounting Bracket Rear Facing Pair Between Frames with Extension	XNPM04
Slack Spool Management	
Slack Spool Management Plastic 5.0" (Qty = 2) Kit	BHSP020
Slack Spool Management Metal 2.5" (Qty = 2) Kit	BHSP030
Cable Management Accessories	
Cable Management Ring Plastic (Qty = 5) 3" x 1.5" Reversible (22991)	XMR01
Cable Management Ring Kit (Qty = 5) 6.5" Wide x 3" Deep	XMR02
Cable Management Ring Kit (Qty = 5) 2.5" Wide x 3" Deep	XMR03
Quick Mount Base (Qty=10) with Fastener, for 1/4" Holes	XCTM
Cabinet Accessories	
Casters Kit (4), Regular Capacity 1,080 lbs	XCK01
Casters Kit (4), High Capacity 2,250 lbs	XCK02
Levelers Kit (4)	XLK01
Bolt-Together Kit for X Series Cabinet	XBK01

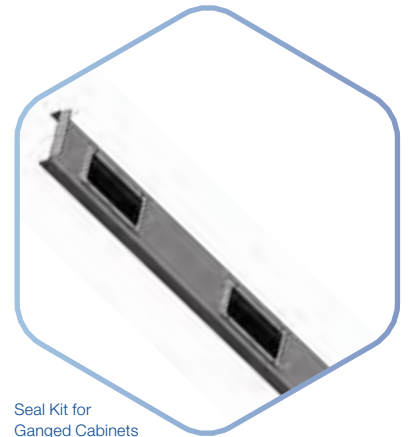

Seal Kit for Ganged Cabinets

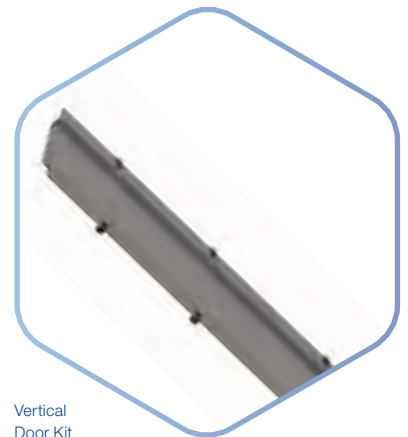

Vertical Door Kit

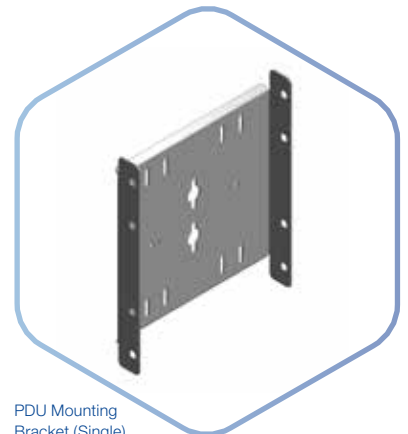

PDU Mounting Bracket (Single)



X-Series Accessories *(continued)*

Belden's XHS Cabinet Series – Cable Management and Zero U Patching

Belden's XHS Series cabinets and cable management components were specifically designed for integration with the Belden IBDN copper and fiber networking system for a true end-to-end solution.

The combination of Belden's extensive cable and connectivity design knowledge and years of interaction with installers and system designers has enabled us to offer:

Features

- A broad selection of modular vertical and horizontal cable managers in configurations that meet your exact requirement for compromise-free hosting
- Flexibility to meet customer needs requiring low to extremely high networking/hosting density
- Modular cable management components and cabinets that protect your investment because they can be reconfigured to meet evolving hosting requirements (typical cabinet system will play host to 3–5 generation active equipment)
- Vertical managers that enable ease of moves, adds and changes, making management of your network fast and precise while still allowing you to maintain an organized, consistent look
- A cable management system designed to maintain proper cable bend radius and minimal tension through the use of support fingers, an attachment point for cable bundles and a slack management spool, ensuring maximum bandwidth from your copper and fiber networks

See page 46 for Horizontal Cable Management options.

Vertical Lacing/PDU Mounting Panel*

- Manager panel 7" and 3.5" wide
- Mounts on rail struts for depth adjustability
- Panels can be mounted side by side to create manager surface
- Tool-less PDU mounting
- Lacing of cable bundles
- Attachment of ring managers
- Attachment of slack management spools
- Attachment of quick mount base

Finger Style Vertical Managers

- Mounts on rail struts for depth adjustability
- Compatible with both 610 mm and 762 mm wide cabinets
- Can be used in cabinet front and rear
- Includes doors to hide cables and provide organized look
- Vertical manager can be oriented two different ways to optimize cable routing

Finger Style Features

- 140 mm wide x 91 mm deep for 129 cm² of cross sectional area
- For medium- and high-density applications
- Management fingers align with mounting rail RU
- Finger allows for cable support and bend radius control
- Oblong opening allows cable routing into the manager

Lacing Panel (close-up)



Vertical Lacing/PDU Mounting Panel
3.5" and 7" wide

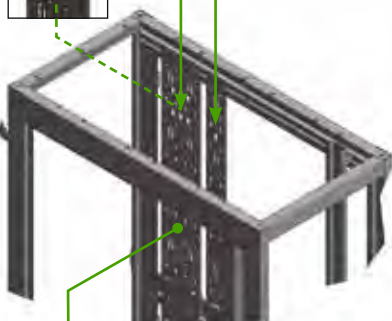

Lacing Panel shown in cabinet

Finger Style Vertical Manager

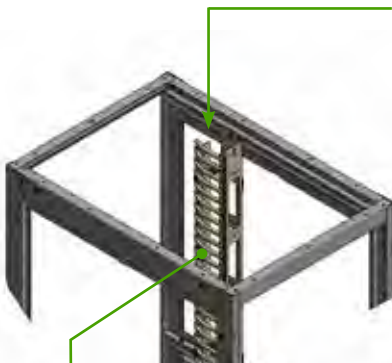

Vertical Manager shown in cabinet



* Lacing-PDU mounting panels (page 57) are not included with the cabinets or the PDU's and need to be ordered separately. PDU's/panels uses tool less "button" style mounting.



XHS-Series

Accessories explicitly used on XHS Cabinets

Vertical Lacing/PDU Mounting Panel

HVMP			
Panel Width	Frame Height	Color	
01 3.5"	42 42RU	01 Black	
02 7"	45 45RU	02 CO White	
	48 48RU		

Vertical Manager – Finger Style (with door)

HVM	02		
Frame Height	Color		
42 42RU	01 Black		
45 45RU	02 CO White		
48 48RU			

Description	Part Number
Other Accessories	
Ring Kits	
Cable Management Ring Plastic (Qty = 5) 3" x 1.5" Reversible	XMR01
Cable Management Ring Kit (Qty = 5) 6.5" Wide x 3" Deep	XMR02
Cable Management Ring Kit (Qty = 5) 2.5" Wide x 3" Deep	XMR03
Fiber Slack Management Spools 6" deep (includes 2 spools)	BHSP020
Fiber Slack Management Spools 2" deep for lacing panels (includes 2 spools)	BHSP030
Quick Mount Base (Qty=10) includes Fastener, for 1/4" Holes	XTCM01
Velcro Cable Ties, 25 per Roll, 8"L	AX100783
Velcro Cable Ties, 25 per Roll, 12"L	AX100784
Vertical Ground Bars	
Vertical Ground Bar, Insulated, 42RU	XVGB0142
Vertical Ground Bar, Insulated, 45RU	XVGB0145
Vertical Ground Bar, Insulated, 48RU	XVGB0148
Miscellaneous	
Casters Kit (4), regular capacity 1080 lbs	XCK01
Casters Kit (4), high capacity 2250 lbs	XCK02
Levelers Kit (4)	XLK01
Bolt together kit for cabinets	8910-0100

Vertical Managers:



X-Series Accessories *(continued)*



Belden Zero U - Vertical patch panel allows for optimal use of mounting space into XHS Series cabinets by providing high-density connectivity options along the equipment mounting rails.

Zero U

Vertical Patch Panel and Connectivity

Features

- Attach to mounting rails
- Vertical patch panels are compatible with Belden copper and fiber connectivity (FX UHD, FX Ultra Frames and Cassettes)

Description	Part Number
-------------	-------------

Other Accessories

Zero U - Vertical Patch Panel and Connectivity	
Vertical Patch Panel (7 positions), Compatible with 24" and 30" Wide XS Cabinets	XZUK01
Vertical Patch Panel (14 positions), Compatible with 30" Wide XS Cabinets	XZUK02
FXUHD KeyConnect Frame Blank	FFZH00BB
FXUHD KeyConnect Frame 6-Port, Black (Empty)	FFZH06KC
FXUHD KeyConnect Frame 8-Port, Black (Empty)	FFZH08KC
10GX KeyConnect Couplers for Vertical Mount Patch Panel, 8-Port, Black	AX105366
CAT6+ KeyConnect Couplers for Vertical Mount Patch Panel, 8-Port, Black	AX105367





XHS-Series

Accessories explicitly used on XHS Cabinets

Front Rail Air Blocker

HS			RSK	
Frame Height		Frame Width		Color
42	42RU	30	30"	01 Black
45	45RU	40	40"	02 CO White
48	48RU			

Finger Strip Kit

Cable management fingers mount to EIA rails front and/or rear. *For One Rail.

HSFS			
Frame Height		Quantity (for 1 rail)	
42	42RU	1	Front rail mount
45	45RU	2	Side rail mount
48	48RU		

Front to Rear Cable Manager

Adjustable-depth front to rear cable managers.

HSFRM	
Color	
01	Black
02	CO White

Top Cable Through with Cover

HS		TT	
Frame Width		Color	
30	30"	01	Black
40	40"	02	CO White

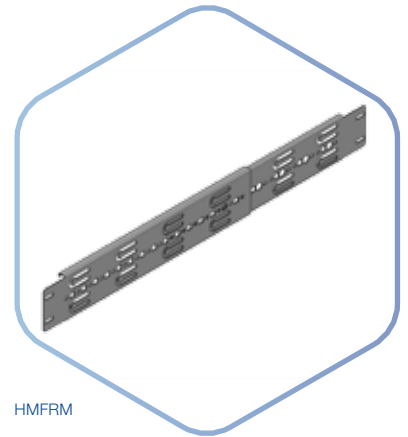

HMFRM

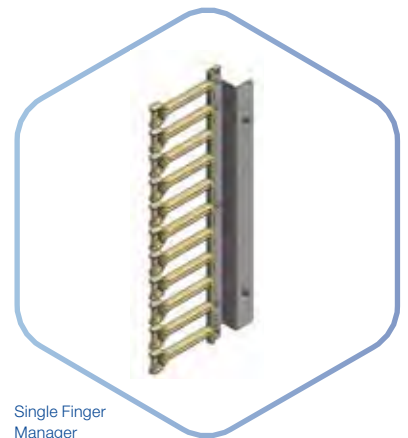

Single Finger Manager

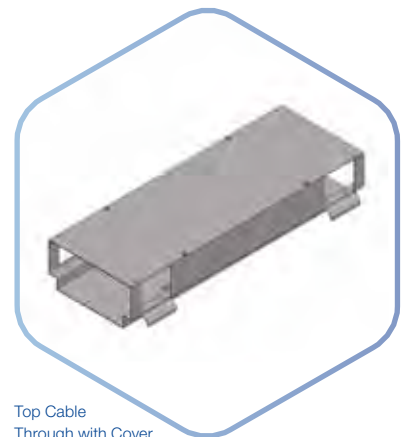

Top Cable Through with Cover (8.5" W x 4.0" H)

Description	Part Number
-------------	-------------

Other Accessories

Front rail air blocker cable pass trough brush kit	
Brush kit (1) for rail air blocker, Black	HSRSBK01
Brush kit (1) for rail air blocker, White	HSRSBK02

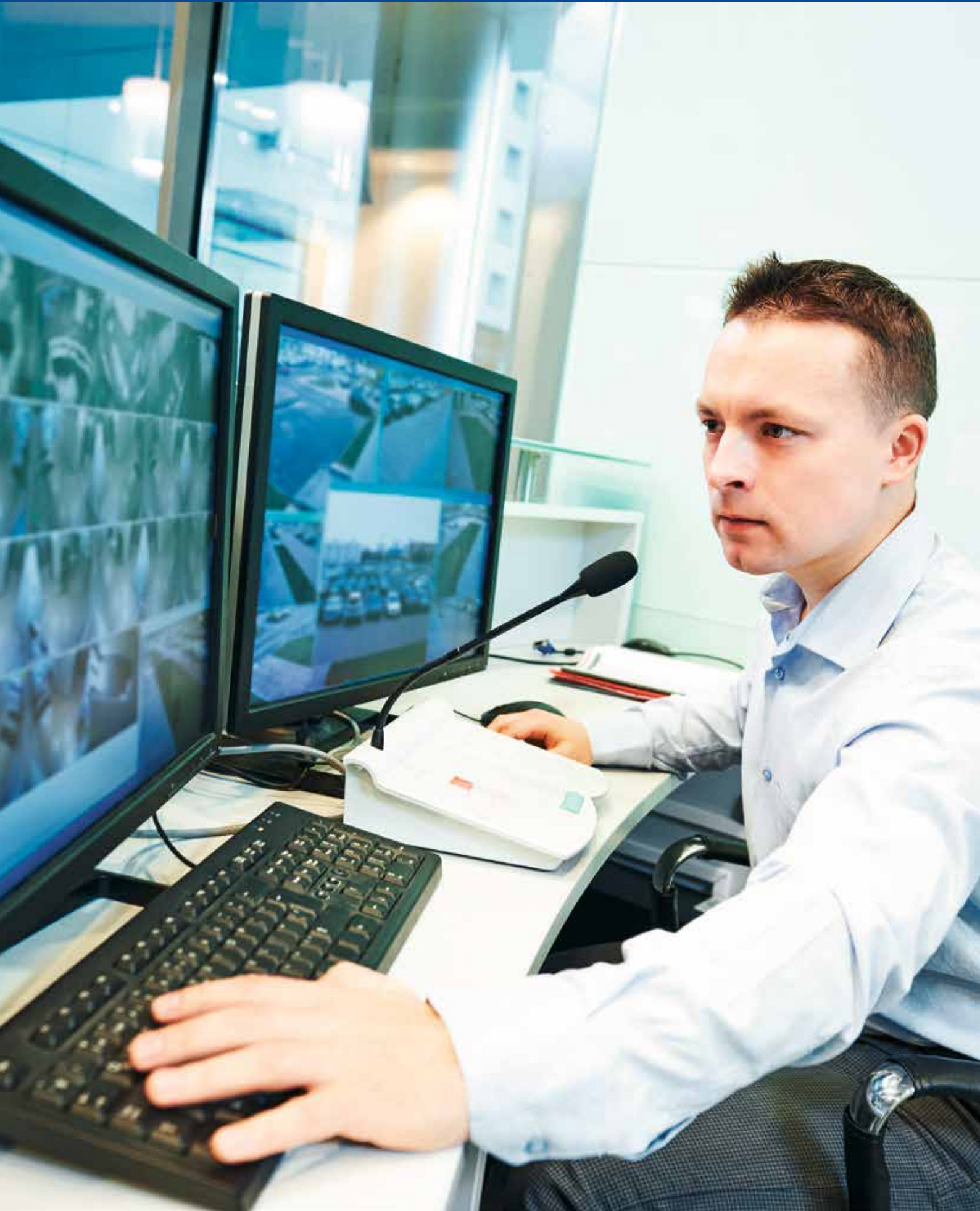



Data Center Solutions Controlling and Monitoring

Section Four

■ Section FOUR – Controlling and Monitoring	
Power Distribution and Climate Monitoring	61-71
Overview	62
Cabinet Power Distribution Units (PDUs)	63
Upgradable Technology	64
Basic PDU	66
Metered PDU	67
Power Monitoring PDU	68
Switched PDUs	69
Environmental Sensors	70
Accessories	71
Aisle Containment	72-75
E-Series Aisle Containment Sliding Doors and Roof System	72-73
X-Series Aisle Containment	74-75
Access Control System for X-Series	76-77

Power Distribution and Climate Monitoring

Power Availability, Distribution, Allocation and Monitoring are Critical Data Center and Broadcast Studio Requirements

Belden in-cabinet mounted Power Distribution Units (PDUs) and Environment Monitors and Sensors are designed from high-quality components to support all your mission critical applications.

Precisely distribute, monitor, analyze and manage power distribution in your facility to maximize processing capacity and promote power efficiency.

A key component of our Data Center Solution Belden PDUs allow configuration of integrated and optimized hosting systems, including fiber/copper connectivity and cabling, cabinets, cable management and air flow management. They are designed to facilitate seamless integration into Belden cabinets and accessories, and include multiple mounting options for maximized air flow and cable management in high-density servers or switch hosting applications.

Paired with our extensive line of environmental monitors and sensors, which include alarm thresholds, reporting functionality, and a built-in intuitive web interface for remote access, Belden has everything you need to precisely monitor, analyze and log key parameters, enabling you to identify current fluctuations and quickly troubleshoot potential problems.





Cabinet Power Distribution Units (PDUs)

The extensive selection of data center PDU power products includes solutions such as upgradeable power distribution units, monitoring sensors and low profile breakers. Whether in need of basic products, or monitored power to help prevent circuits from overloading, a comprehensive range enables a suited solution for every situation.

Basic PDUs

Basic PDUs offer reliable power distribution to the cabinet to help manage power capacity and increase functionality. Get instant power usage feedback by adding a local display to avoid overloads and costly downtime.

Monitored PDUs

Power monitoring provides a comprehensive view of power usage in a data center. The local display, combined with remote power monitoring, offer quick access to the PDU's current, volts, real power, apparent power, power factor, and kilowatt hours.

Optional Remote Sensing enables amongst others temperature, air flow and other environmental condition monitoring.

Metered PDUs

Improve reliability, energy efficiency, and prevent crippling downtime caused by overloads using Metered PDUs. Equipped with local digital displays, our Metered PDUs provide power consumption metrics instantly.

Switched PDUs

Switched PDUs offer the ability to monitor data locally and remotely and disable individual power outlets, as necessary. Disable problem equipment by cutting power to specific outlets and reboot equipment remotely by cycling power.

Optional Remote Sensing enables amongst others temperature, air flow and other environmental condition monitoring.



Detailed of Monitored PDU with remote sensing option

Functionality Matrix

Feature	Basic	Metered	Monitored	Switched		
Power Distribution	•	•	•	•		
Current Meter(s)		•	•	•		
VLC Enabled		•	•			
Network Interface			•	•		
Environmental Monitoring			Optional	Optional		
Outlet-Level Monitoring			Optional	Optional		
Outlet-Level Switching				•		
Upgradeable	•	•	•			
U-Lock Outlets	•	•	•			
1U and Zero U Configurations	•	•	•	•		
Color Coded PDUs	■	■	■	■	■	■

* Standard color is Black.

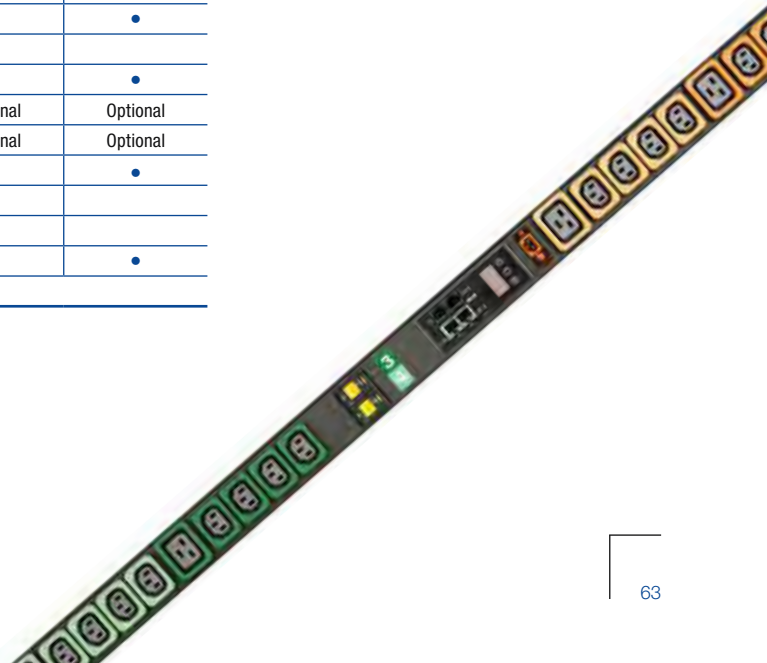

Power Distribution and Climate Monitoring *(continued)*



Hot Swapable
Monitoring Device
close up

Upgradable Technology

Belden Upgradeable PDUs give data center managers the flexibility to install the intelligence they require today with the option to upgrade technology as needs evolve. From basic power to sophisticated power monitoring with remote sensors, the Belden Upgradeable product line adapts to your business well into the future.

Upgradeable Monitoring

Begin with the level of technology you need today and upgrade as your needs evolve, without replacing the entire PDU.

Hot-Swappable

Add, remove or switch Hot Swapable Monitoring Device (HSMD) without interrupting power to critical equipment.

High Temperature Grade

60°C working ambient variants for high temperature environments.

Remote Sensor Port

Monitor environmental conditions such as airflow, temperature, humidity and dew point with the use of a Belden remote sensor.

Input Power Monitoring 1% Accuracy (ANSI and IEC)

Allows data center managers to accurately reconcile power usage.

Fault-Tolerant Daisy Chaining

Simplifies intelligent PDU connectivity and ensures data is reported, even with a break in the chain.

Lockable Receptacles

Securely lock cords in place using the Lockable technology. Each receptacle is color injected to assure load balancing is easily achieved.

Red LED Rotatable Display

Read power data easily in dimly lit areas and rotate the display to match the mounting configuration.

Low-Profile Breakers

Compact profile to install in tight spaces for units requiring breakers.



Upgradeable Path

There is a clear route to upgraded functionality of your Belden PDUs. Simply choose the functionality that suits today's requirements and the future proof solutions allow to upgrade to the next, most sophisticated level at a later date. To establish this extraordinary upgrade path, Belden incorporated an Hot Swappable Monitoring Device (HSMD) into its robust PDU design. Belden's rugged power strips last for years and with the new HSMD users can install the latest technology without replacing the power strip. The hot-swappable HSMD can be changed in a few simple steps without interrupting power to critical servers.



Basic

Start with the basic up-gradeable unit if your facility is not yet ready for power monitoring, but there are future development plans. With the technology built in, you can add functionality when the timing is right.

Metered

Metered PDUs offer local power monitoring.

Power Monitoring

Offers local and remote power monitoring: the perfect first step towards increasing PDU functionality.

Power Monitoring + Remote Sensing

The HSMD allows remote power monitoring that adds the ability to connect up to four remote sensors – ideal for installations requiring environmental monitoring.

NOTE: This image above shows which families will be available for upgradable technology.

Ordering Information Hot Swappable Monitoring Device (HSMD)

Part Number	Category
Metered	
PDU-12365	Metered Hot Swappable Monitoring Device for Horizontal Units
PDU-12364	Metered Hot Swappable Monitoring Device for Vertical Units
Monitored	
PDU-11213	Power Unit Level Monitoring Hot Swappable Monitoring Device for Horizontal Units
PDU-11150	Power Unit Level Monitoring Hot Swappable Monitoring Device for Vertical Units
Monitored plus Remote Sensing	
PDU-11540	Power Monitoring Plus Remote Sensing Hot Swappable Monitoring Device for Horizontal Units
PDU-11541	Power Monitoring Plus Remote Sensing Hot Swappable Monitoring Device for Vertical Units

Power Distribution and Climate Monitoring *(continued)*

Basic PDU

Belden Basic PDUs offers reliable power distribution to the cabinet to help manage power capacity and increase functionality. Get instant power usage feedback by adding a local display to avoid overloads and costly downtime when moving critical equipment.

Basic Upgradeable PDU

The Belden Upgradeable power strips give data center managers the flexibility to install the intelligence they require today with the option to upgrade technology as needs evolve.



Ordering Information

Part Number	Category	Sub Category	Volts	Amps	Plug Form	Configuration	Receptacle Qty 1	Receptacle Type 1	Receptacle Qty 2	Receptacle Type 2	Breaker	Color
Basic												
Standard												
PDU-3044	Basic	Standard	230V	16A	2P+E (IP44)	Horizontal/Vertical	8	IEC C13	0	0	No	Black
PDU-10402	Basic	Standard	230V	13A	BS1363	Horizontal	8	BS1363	0	0	No	Black
PDU-10515	Basic	Standard	230V	32A	2P+E (IP44)	Vertical	20	IEC C13	4	IEC C19	Yes	Black
PDU-10813	Basic	Standard	230V	16A	Schuko	Horizontal	6	German Schuko	0	0	No	Black
Upgradeable												
PDU-11875	Basic	Upgradeable	230V	32A	2P+E (IP44)	Horizontal	12	Locking IEC C13	4	Locking IEC C19	Yes	Black
PDU-12225	Basic	Upgradeable	230/400V WYE	32A	3P+N+E (IP44)	Vertical	36	Locking IEC C13	6	Locking IEC C19	No	Black



Metered PDU

Improve reliability, energy efficiency, and prevent crippling downtime caused by overloads using Belden's Metered PDUs. Equipped with local digital displays, our Metered PDUs provide power consumption metrics instantly, ideal for when deploying or moving critical server equipment.

Like all Belden PDUs, our Metered PDUs cater to a wide range of power input and output requirements to distribute 100-240V to multiple outlets. The Metered PDUs are available in various horizontal and vertical configurations to meet your accessibility needs.

Metered Upgradeable PDU

The Belden Upgradeable power strips give data center managers the flexibility to install the intelligence they require today with the option to upgrade technology as needs evolve.

Equipped with a digital current meter, the Metered PDU provides local load monitoring and helps to avoid potential overloads while providing reliable, rack-mount (zero U or 1U), multi-locking receptacle, single or three-phase, power distribution from any protected UPS, generator or mains input power source.



Ordering Information

Part Number	Category	Sub Category	Volts	Amps	Plug Form	Configuration	Receptacle Qty 1	Receptacle Type 1	Receptacle Qty 2	Receptacle Type 2	Breaker	Color
Metered												
Standard												
PDU-10670	Metered	Standard	230V	13A	BS1363	Vertical	10	BS1363			No	Black
PDU-10470	Metered	Standard	230V	16A	2P+E (IP44)	Horizontal	12	IEC C13	4	IEC C19	No	Black
PDU-10444	Metered	Standard	230V	16A	2P+E (IP44)	Vertical	12	BS1363			No	Black
PDU-2643	Metered	Standard	230V	32A	2P+E (IP44)	Vertical	24	IEC C13	6	IEC C19	Yes	Black
Upgradeable												
PDU-12099	Metered	Upgradeable	230V	16A	2P+E (IP44)	Vertical	12	Locking IEC C13	6	Locking IEC C19	No	Black
PDU-12333	Metered	Upgradeable	230/400V WYE	16A	3P+N+E (IP44)	Horizontal	12	Locking IEC C13	6	Locking IEC C19	No	Black
PDU-12336	Metered	Upgradeable	230/400V WYE	16A	3P+N+E (IP44)	Vertical	36	IEC C13	6	IEC C19	No	Black



Power Distribution and Climate Monitoring *(continued)*

Power Monitoring PDU

Simply capture all the data needed to analyze trends and resolve issues before they lead to costly downtime. Optional environmental sensors provide the ability to track critical climate variables such as temperature, airflow, humidity and dew point. Remote power and environmental monitoring information is available through any Web browser so no external software is required.

Outlet Level Power Monitoring

Outlet measurements can be used to accurately reconcile power usage per rack for a customer or department. Use these measurements to verify SLAs or for budgeting purposes; the measurements have been tested and verified by ANSI C12.1 and IEC 62053-21 to meet 1% Accuracy Class requirements.

Belden's units support SNMP (v1, v2c, v3) and allows the data to easily integrate with Data Center Infrastructure Management (DCIM) systems or receive alerts when thresholds are breached.

Upgradeable Unit Level Power Monitoring

The Belden Upgradeable PDUs adapts to your business well into the future. Simply choose the functionality that suits your requirements today with the flexibility to install technology as needs evolve.

With remote power monitoring, data center managers can receive notifications of current threshold breach, preventing unnecessary downtime. Data from the unit can be accessed through any Web browser, without requiring external software. Data can be integrated into Simple Network Management Protocol (SNMP) systems for remote notification, and the intuitive

graphical user interface (GUI) allows managers to quickly access pertinent information.

Upgradeable Local and Remote Power Monitoring + Remote Sensing

The unit's environmental sensor port gives data center managers the ability to track critical climate variables like temperature, airflow, humidity and dew point with the use of a Geist remote sensor. With hot-swappable upgrade technology, users may easily upgrade PDUs to the latest available technology by replacing the HSMD module; all without causing any interruption.

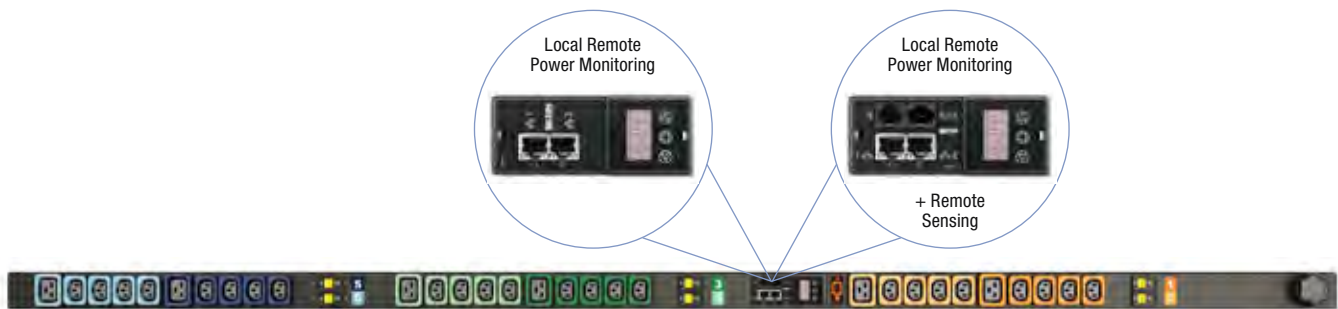

Ordering Information

Part Number	Category	Sub Category	Volts	Amps	Plug Form	Configuration	Receptacle Qty 1	Receptacle Type 1	Receptacle Qty 2	Receptacle Type 2	Breaker	Color
Monitored												
Upgradeable Unit Level												
PDU-11623	Monitored	Upgradeable Unit Level	230V	16A	2P+E (IP44)	Vertical	20	BS1363 Right	0	0	No	Black
PDU-11861	Monitored	Upgradeable Unit Level	230V	16A	2P+E (IP44)	Vertical	20	Locking IEC C13	6	Locking IEC C19	No	Black
PDU-11316	Monitored	Upgradeable Unit Level	230V	32A	2P+E (IP44)	Vertical	36	IEC C13	6	IEC C19	Yes	Black
Upgradeable Unit Level + Remote Sensing												
PDU-11804	Monitored	Upgradeable Unit Level EC	230/400V WYE	32A	3P+N+E (IP44)	Vertical	24	Locking IEC C13	6	Locking IEC C19	Yes	Black
PDU-11862	Monitored	Upgradeable Unit Level EC	230V	16A	2P+E (IP44)	Vertical	20	Locking IEC C13	6	Locking IEC C19	No	Black
PDU-11879	Monitored	Upgradeable Unit Level EC	230V	32A	2P+E (IP44)	Vertical	30	Locking IEC C13	6	Locking IEC C19	Yes	Black
Outlet Level												
PDU-11245	Monitored	Outlet Level	230V	32A	2P+E (IP44)	Vertical	18	Locking IEC C13	6	Locking IEC C19	Yes	Black
PDU-10940	Monitored	Outlet Level	230/400V WYE	32A	3P+N+E (IP44)	Vertical	12	Locking IEC C13	12	Locking IEC C19	Yes	Black



Switched PDUs

Belden switched PDUs provide hands-on control. While monitored PDUs can display information remotely, only switched PDUs offer the ability to use that data and disable individual power outlets. Manage critical issues that arise with the click of a few buttons. Disable problem equipment by cutting power to specific outlets, reboot equipment remotely by cycling power, and save time and money by avoiding sending technicians to the source of the issue.

Switched Outlet Level Monitoring

The outlet level monitoring PDUs track granular power consumption data of all equipment. The Max Group Amps (MGA) feature offers an extra level of protection, preventing circuit overload by letting users set the threshold for maximum number of amps.

Simply capture the data needed to analyze trends and resolve issues before they lead to costly downtime. With a click of a few buttons users can disable problem equipment by cutting power to specific outlets, rebooting equipment remotely. With flexible access rights and security settings, create and manage user accounts to promptly handle issues when they arise.

Switched Unit Level Monitoring

The Switched unit level monitoring serie can also control (switch on and off) individual receptacles, while it provides a comprehensive view of power usage in a data center.

Ordering Information

Part Number	Category	Sub Category	Volts	Amps	Plug Form	Configuration	Receptacle Qty 1	Receptacle Type 1	Receptacle Qty 2	Receptacle Type 2	Breaker	Color
Switched												
Unit Level												
PDU-10776	Switched	Unit Level Monitoring	230V	16A	2P+E (IP44)	Vertical	20	Locking IEC C13	4	Locking IEC C19	No	Black
PDU-11246	Switched	Unit Level Monitoring	230V	32A	2P+E (IP44)	Vertical	20	Locking IEC C13	4	Locking IEC C19	Yes	Black
PDU-8421	Switched	Unit Level Monitoring	230/400V WYE	16A	3P+N+E (IP44)	Vertical	21	Locking IEC C13	3	Locking IEC C19	No	Black
PDU-8422	Switched	Unit Level Monitoring	230/400V WYE	32A	3P+N+E (IP44)	Vertical	21	Locking IEC C13	3	Locking IEC C19	Yes	Black
Outlet Level												
PDU-10820	Switched	Outlet Level Monitoring	230V	16A	2P+E (IP44)	Vertical	20	Locking IEC C13	4	Locking IEC C19	No	Black
PDU-8426	Switched	Outlet Level Monitoring	230/400V WYE	32A	3P+N+E (IP44)	Vertical	21	Locking IEC C13	3	Locking IEC C19	Yes	Black

Power Distribution and Climate Monitoring *(continued)*



Environmental Monitors and Sensors



9318-0500



9318-0560



9318-0570

Applications

- Belden climate monitors and sensors allow precise monitoring/alarming of key environmental parameters for improved equipment availability in mission critical applications (Data Center, networking closet, remote locations)
- Built-in intuitive web interface for remote access via Ethernet browser
- Built-in and external sensor options (temperature, humidity, air flow, water detection, door position, smoke)
- SNMP-enabled for compatibility with leading DCIM package
- Recognize IP-based camera for space viewing
- Set alarm threshold, can be sent to up to five e-mail addresses
- Allows viewing of data graphs and analysis of historical logs
- Power supply included
- UL and cUL listed

CE Plug and Receptacle Configuration

IEC				
Amp	Volt	Power Inlet	Power Receptacle	
15/10*	125 OR 250	C-14	C-13	
20/16*	125 OR 250	C-20	C-19	
Amp	Volt	Pin and Sleeve Plug	Pin and Sleeve Receptacle	
20/16*	250/230*	2P+E	2P+E	
30/32*	250/230*	2P+E	2P+E	
60/63*	250/230*	2P+E	2P+E	
20/16*	230/400* x 3~ WYE	3P+N+E	3P+N+E	
30/32*	230/400* x 3~ WYE	3P+N+E	3P+N+E	

* Rating for CE products



Accessories

Description	Part Number
Other Accessories	
Environmental Monitors	
Compact Self-Contained Environmental Monitor (5.25"Lx1.75"Hx1.5"W); Provides Web-Based Remote Surveillance with On-Board Temperature and Humidity/Dew Point Sensors. Has Input Capacity for Two External Sensors	9318-0500
Rack Mount 1RU Environmental Monitor. Provides Web-Based Remote Surveillance of Temperature, Relative Humidity, Dew Point, Airflow, Light, Sound. Up to (5) Additional Digital Sensors Can Be Connected to the Unit	9318-0540
Rack Mount 1RU Environmental Monitor. Provides Web-Based Remote Surveillance of Temperature, Relative Humidity, Dew Point, Airflow, Light, Sound. Up to (5) Additional Digital Sensors Can Be Connected to the Unit. Comes Equipped with an LCD Display with Scrolling Measurements and a Built-In Audible Alarm	9318-0560
Rack Mount 1RU Environmental Monitor. Provides Web-Based Remote Surveillance of Temperature and any Additional Sensors Connected to the Unit. Comes Equipped with (4) Digital and (6) Analog Sensor Ports, an LCD Display with Scrolling Measurements, Built-In Audible Alarm and (3) Relay Output Ports	9318-0570
Environmental Monitors Accessories	
19" Rack Mount 16-Way Splitter, 1RU for RJ12 Sensors	9318-0510
Remote PDU Display, RJ12 Connection	9318-0506
Sensors (compatible with environmental monitors and intellignet PDU)	
Remote Temperature Sensor with 12 Ft. Wire	9318-0501
Remote Temperature Sensor with 20 Ft. Wire	9318-0510
Remote Temperature Sensor with 50 Ft. Wire	9318-0511
Remote Temperature/Air Flow/Humidity and Dew Point Sensor with 12 Ft. Wire	9318-0503
Remote Temperature/Air Flow/Humidity and Dew Point Sensor with 20 Ft. Wire	9318-0515
Remote Temperature/Air Flow/Humidity and Dew Point Sensor with 50 Ft. Wire	9318-0516
Remote Door Position Analog Sensor	9318-0504
Remote Water Detection Analog Sensor	9318-0505
DLinks Web Camera Kit	9318-0509
Temperature Displays (local monitoring only)	
19" Rack Mount Temperature Display with Thermocouple; 1RU Blanking Panel Type	9318-0512
Temperature Display with Thermocouple; 1.72"H x 3.8"W x 1.1"D	9318-0513



9318-0506
Remote PDU Display



DLinks Web
Camera Kit



Top:
9318-0503
Temp/Air Flow/Humidity Remote Sensor
Bottom:
9318-0513 Temperature Display
with Thermocouple

Description	Part Number
Power Cord Management	
Cable Management Ring Plastic (Qty = 5) 3" x 1.5" Reversible	XMR01
Cable Management Ring Kit (Qty = 5) 2.5"W x 3"D	XMR03
Slack Management Spool Kit (includes 2 spools)	BHSP020
Quick Mount Base (Qty=10) with Fastener, for 1/4" Holes	XCTM
Velcro Cable Ties, 25 per Roll, 8" L x 0.5"W	AX100783
Velcro Cable Ties, 25 per Roll, 12" L x 0.5"W	AX100784

Aisle Containment

E-Series Aisle Containment Sliding Doors and Roof System

EAC Series

Application

It is critical to optimize the cooling system of installed equipment in a datacenter. Uncontrolled air flow is inefficient and influences the performance of the data center. By separating cold air supply from dissipated hot air from the equipment, this can be prevented. A very effective way is to use aisle containment by to prevent hot and cold air from mixing together. The aisles are sealed off by a roofing system and sliding doors.

This EAC Aisle containment package is compatible with the E-Series cabinet series ESH (1800 kg version) and ESN (1200 kg version). For the ESN serie, the aisle must be installed on the rear side of the cabinet.



Installed
Sliding doors
and Roofs

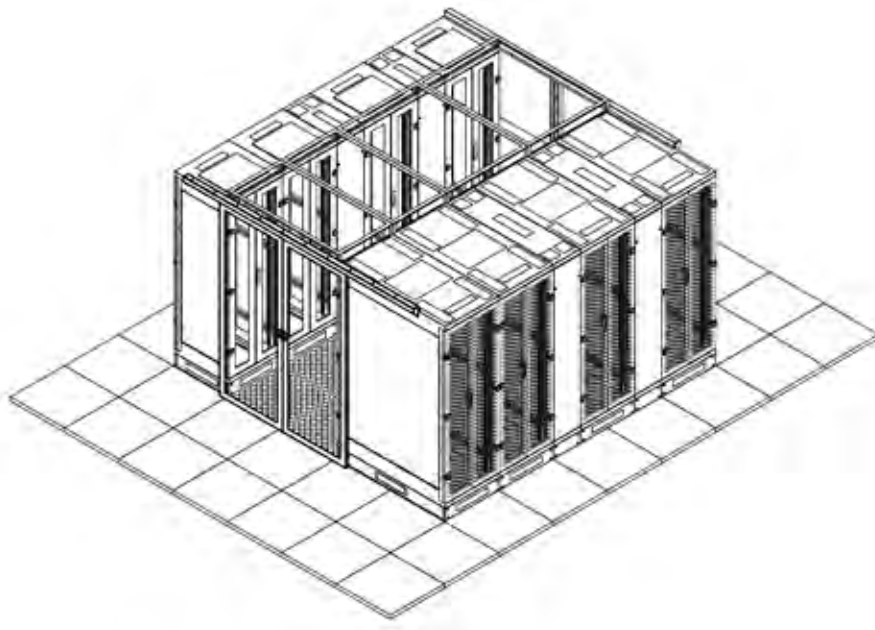

Features

- Aisle containment for hot and cold air separation
- Seal off by sliding doors and roofing system
- Various widths depths and heights
- Supporting ETSI Footprint
- Customization possible





Sliding Doors

The doors are self-supporting and need the cabinets for stability.

To seal off the aisle, the sliding double sided doors have clear safety glass.

The standard span width is 1200 mm for practical reasons, and provides enough space for maintenance, opening doors on both sides. The doors are for heights of 42, 45 and 47 Units.

The sliding door is available as manual closing or automatic closing (based on Gas-spring mechanism).

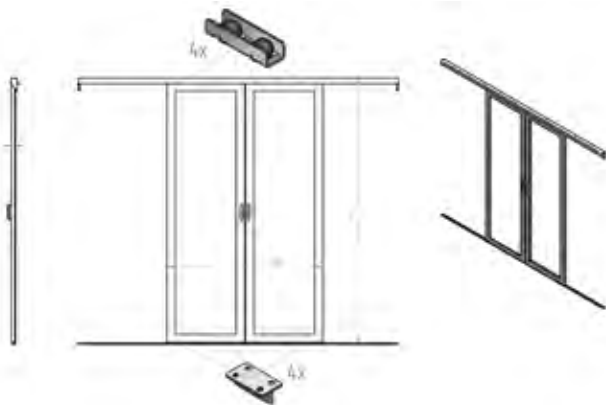

Ordering Information

Accessory Cabinet		Span		Height	
EAC	Aisle Containment	S	1200 mm	42	42U
				45	45U
				47	47U

EAC	M	S	42	1
------------	----------	----------	-----------	----------

Section		Color	
M	Manual Sliding Door	1	Gray RAL 7035
G	Self-Closing Door	2	Black RAL 9005

Roofing

The aisle roof is made of clear safety glass in a metallic frame. A ceiling shape allows an air to flow easily.

The standard span is 1200mm for the aisle to a width from 300 mm to 800 mm to cover the ETSI footprint.

The roofs weigh completely on the cabinets.

Installation instructions are provided for a proper handling.

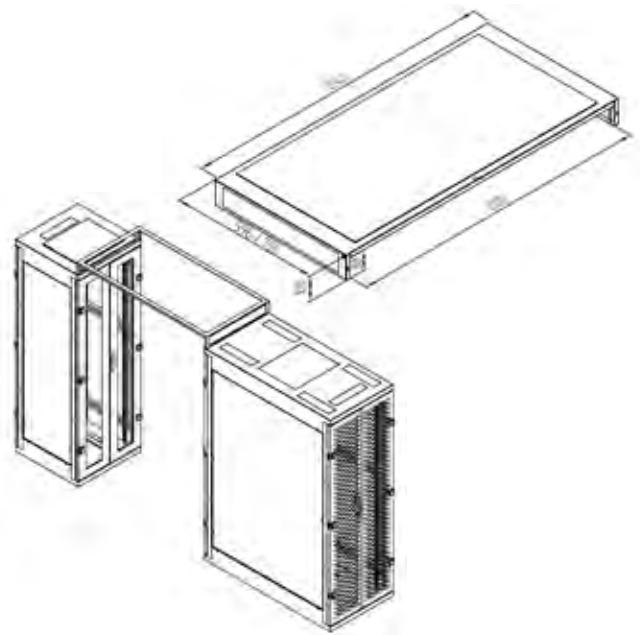

Ordering Information

Accessory Cabinet		Span		Width	
EAC	Aisle Containment	S	1200 mm	3	300 mm
				4	400 mm
				6	600 mm
				8	800 mm

EAC	R	S	6	1
------------	----------	----------	----------	----------

Section		Color	
R	Roof Cover	1	Gray RAL 7035
		2	Black RAL 9005

Aisle Containment



X-Series Aisle Containment

Belden's Aisle Containment solutions eliminate mixing of hot and cold air in data center environments to maximize energy efficiency and lower operating costs. Our aisle containment systems are vendor agnostic, featuring innovative transparent panels that are lightweight and easily attached horizontally or vertically to data center cabinets using a universal rail system. The panels are field modifiable to meet varying height and space requirements between rows of cabinets and from the top of the cabinets to the ceiling. The aisle containment systems can also interact with smoke or fire alarm systems to ensure proper operation of critical fire suppression and safety systems.

Solutions offered are for both hot and cold aisle containment system.



Vertical Containment

Vertical panels direct hot return air to overhead return plenum, eliminating mixing and improving overall operating efficiency of perimeter CRAC units. Using a fully ducted cold air delivery system with vertical panels also allows for cold air to be placed directly into the cold aisle, eliminating the need to use the underfloor space for supply air.

Horizontal Containment

For raised-floor environments with overhead obstructions or no ceiling plenum, non-ducted panels form a roof to trap cold air, enabling higher supply temperatures and maximizing available cooling. This design can also be used for data centers utilizing in-row cooling solutions.

Aisle Doors

Belden offers both swinging and sliding door options in the S-Series for the end of the row.

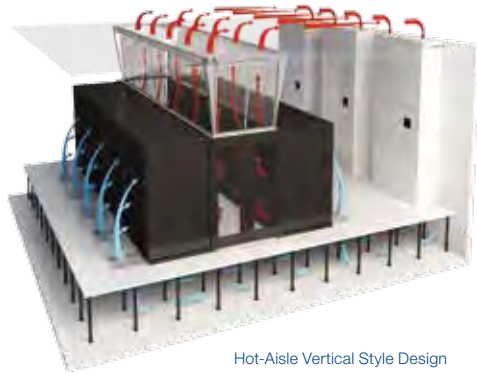

Hot-Aisle Vertical Style Design

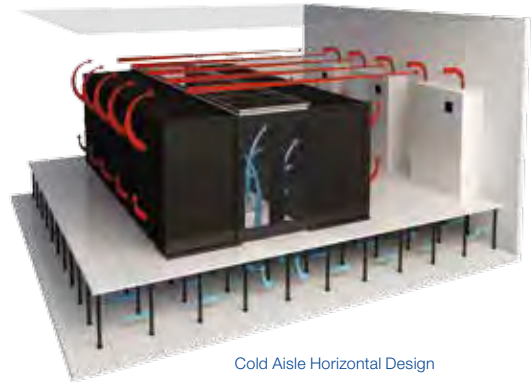

Cold Aisle Horizontal Design

Vertical Style Heat Containment

Part number example from configuration shown below:

XSAC1143.720032

Fixed Letter Series	1. Choose Cabinet Series	Fixed Letters	2. Choose pod type	3. Choose containment panel type	4. Measure distance cabinet to ceiling	5. Enter aisle length	7. Choose aisle width	8. Choose door type
X	S	AC	1	1	43.7	200	3	2
	Cabinet Series End^{1,9}		Hot Air/Cold Air²	Panel Orientation³	Vertical Panel⁴	Aisle Length in inches⁵	Aisle Width⁶	Door Options⁷
	C C-Series		1 Hot Aisle	1 24" Vertical Fixed Black	### Ceiling Height		1 48	1 Swing Door Black
	M XM-Series		2 Cold Aisle	2 24" Vertical Fixed White	### Cabinet Height		2 54	2 Swing Door White
	N XN-Series			3 24" Vertical Hinged Black			3 60	3 Sliding Door Black
	S XS-Series			4 24" Vertical Hinged White			4 66	4 Sliding Door White
	Z Custom						5 72	

Notes:

- Enter the end of row cabinet for mounting door, (will have to know top and side attachment points of customer cabinet)
- Enter cabinet pod type, cold air or hot air containment
- Enter containment panel type
- Enter aisle width or custom width in inches
- Enter aisle length in inches, there will be a trim piece for panels under 24"
- Enter aisle width or custom width in inches, custom widths available on request
- Enter door type, sliding or swing, must enter cabinet end of row type for mounting of doors
- Custom colors available on request
- There may have to be modifications to customer cabinets at location

Horizontal Flat Heat Containment Tops

Part number example from configuration shown above:

XSAC11052004333

Fixed Letter Series	1. Choose Cabinet Series	Fixed Letters	2. Choose pod type	3. Measure distance cabinet to ceiling	4. Enter aisle length	5. Choose exhaust option 1	6. Choose quantity option 1	7. Choose aisle width	8. Choose door type
X	S	AC	1	105	200	4	3	3	3
	Cabinet Series End^{1,11}		Hot Air/Cold Air²	Height Cabinet to Ceiling³	Aisle Length in inches⁴	Exhausting per row^{5,12}	Quantity of Option 1	Aisle Width⁷	Door Options⁷
	C C-Series		1 Hot Aisle	### Ceiling Height		0 None	0 5	1 48	1 Swing Door Black
	M XM-Series		2 Cold Aisle	### Cabinet Height		1 10" fan	1 6	2 54	2 Swing Door White
	N XN-Series					2 Chimney Adapter	2 7	3 60	3 Sliding Door Black
	S XS-Series					3 AEHC Heat Containment	3 8	4 66	4 Sliding Door White
	Z Custom						4 9	5 72	

Notes:

- Enter the end of row cabinet for mounting door, (will have to know top and side attachment points of customer cabinet)
- Enter cabinet pod type, cold air or hot air containment
- Enter ceiling height and (cabinet height (3 options)
- Enter aisle length or custom width in inches
- Enter fan or chimney adapter, or AEHC Heat Containment (Chimney sold separately)
- Enter only 1 number 0-9 (there are 2 columns)
- Enter aisle width
- Enter door type, sliding or swing, must enter cabinet end of row type for mounting of doors
- Custom colors available on request
- Pods will all come with solid horizontal panels unless using (option 1)
- There may have to be modifications to customer cabinets at location



Access Control System for X-Series

Application

Physical assets protection/access is key to IT operations, such as Data Centers, Enterprise and Remote Computing locations. Belden cabinets can be equipped with a variety of locking handles, including state-of-the-art cabinet access control and management solutions, allowing conformance to privacy rules and regulations (PCI DSS, HIPAA, FISMA and more).

Features

- Centralized administration of up to thousands of units
- Real-time monitoring and alerts
- Indisputable audit trails
- Cabinets or row/pod level access
- Flexibility to choose between fingerprint or RFID card access

Stand alone cabinet access systems are for smaller or distributed installations. Each cabinet has a dedicated controller and biometric (BioLock) or card reader (CardLock) used for user authentication.

In a networked cabinet access system, a central controller distributes control signals and power to up to 32 cabinets when authenticating at the cabinet level and 31 cabinets when authenticating at the end of row. For cabinet level authentication, choose between fingerprint (BioLock) or RFID card (CardLock). For end-of-row authentication, the user enters which cabinet door they are attempting to access, then uses any combination of PIN, RFID card and fingerprint to authenticate.

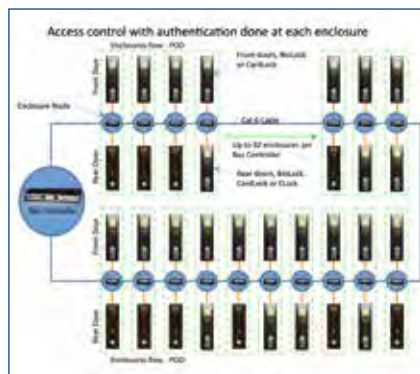

Access control with authentication done at each cabinet



Access control with authentication done at end of row of cabinet



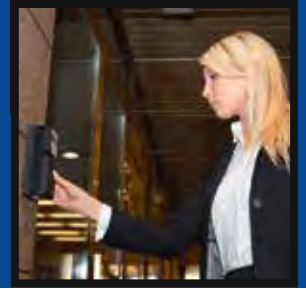

Description	Part Number
Cabinet Access Systems	
Locking Swing Handles	
Swing Handle (1) w/Common CH-751 Lock Cylinder/Key, w/Belden Logo Silk Screen	8815-0100
Swing Handle (1) w/Special Non CH-751 Lock Cylinder/Key, w/Belden Logo Silk Screen	8815-0101
Swing Handle (1) w/Key Lock and Padlock Loop (1), Padlock Not Included	8815-0102
Swing Handle (1) w/3 Digit Combination Lock and Key Override	8815-0103
Smart Lock/Access System	
BUS Controller, includes 48 VDC PSU, 2 x 45 meter CAT 6 Cable	8815-0200
End of Rows Reader	
BUS Enline Reader w/PIN and Fingerprint	8815-0210
BUS Enline Reader w/PIN, Fingerprint and HID ICLASS 13.56 MHz	8815-0211
BUS Enline Reader w/PIN, Fingerprint and HID 125 KHz	8815-0212
Cabinets Level and Row Level Access Systems – Networked Application	
Cabinet Node w/1 Biolock Swing Handle	8815-0221
Cabinet Node w/1 Biolock and 1 Elock Swing Handle	8815-0222
Cabinet Node w/2 Biolocks Swing Handle	8815-0223
Cabinet Node w/1 Cardlock Swing Handle	8815-0224
Cabinet Node w/1 Cardlock and 1 Elock Swing Handle	8815-0225
Cabinet Node w/2 Cardlocks Swing Handle	8815-0226
Cabinet Node w/1 Elock Swing Handle	8815-0227
Cabinet Node w/2 Elocks Swing Handle	8815-0228
Cabinets Level Access Systems – Stand Alone Application	
Access Controller w/1 Cardlock, 18.5 V PSU, 1 Door Switch	8815-0240
Access Controller w/1 Cardlock, 1 Elock, 18.5 V PSU, 2 Door Switches	8815-0241
Access Controller w/2 Cardlocks, 18.5 V PSU, 2 Door Switches	8815-0242
Access Controller w/1 Biolock, 18.5 V PSU, 1 Door Switch	8815-0243
Access Controller w/1 Biolock, 1 Elock, 18.5 V PSU, 2 Door Switches	8815-0244
Access Controller w/2 Biolocks, 18.5 V PSU, 2 Door Switches	8815-0245
Software – Access Interface and Management	
Server/Client Software for Connection up to 10 Cabinets	8815-0280
Server/Client Software for Connection up to 50 Cabinets	8815-0282
Server/Client Software for Connection up to 100 Cabinets	8815-0283
Server/Client Software for Connection up to 250 Cabinets	8815-0284
Electronic Slide Handle	
Electronic Slide Handle (TZ compatible) with Multiport Link and Lock Cylinder	8815-0104

Note: Includes door switch(es) and 45 meter of Cat 6 cables.



8815-0210
BUS Enline Reader
w/PIN and Fingerprint



iClass Card,
Biometrics and
E-Lock Handle Options

BELDEN
SENDING ALL THE RIGHT SIGNALS



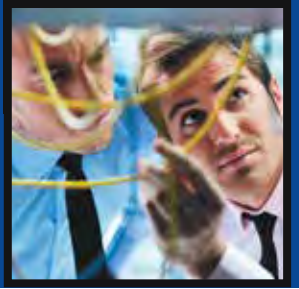

Section Five

■ Section FIVE – Runway Solutions

Cable Runway	79-83
Universal-Style 250 Cable Runway	80
Telco-Style Cable Runway	80
UL Classified Cable Runway	81
Quick Ship Cable Runway Bundle	81
Cable Runway Radius Bend	81
Cable Runway E-Bend	82
Movable Cross Member	82
Cable Runway Radius Drop	83
Cable Spool Divider Kit	83
Junction Kits	84-89
Butt-Splice Kit	84
Heavy-Duty Butt-Splice Kit	84
Junction-Splice Kit	85
Heavy-Duty Junction-Splice Kit	85
90° Runway-Splice Kit	86
45° Runway-Splice Kit	86
Adjustable Junction-Splice Kit	86
Swivel Splice Kits	87
Cable Runway Corner Bracket	88
Cable Runway Closing Kit	88
Cable Runway End Cap	89
Retaining Post For Cable	89
Support Brackets	90-99
Cable Runway Wall to Rack Kit	90
Wall Angle Support Kit, Cable Runway	90
Triangular Support Bracket, Aluminum	91
Triangular Support Bracket, Steel	91
3" Channel Rack-to-Runway Mounting Plate	92
Cable Runway Elevation Kit	92
Cable Runway Standoff Support Kit	93
Vertical Wall Brackets	93
Cable Runway Pipe Stand	93
Framing Clamp Kit	94
Runway Center Support Kit	94
Ceiling Attachment Kit	95
Support Bracket for Runway	95
Ceiling Support Bracket	95
Threaded Rods	96
Coupler for Threaded Rod	96
Threaded Rods Cover	96
J-Bolt Kit, Auxiliary Framing Channel/Rack Top Bar	97
J-Bolt Clip Kit, Auxiliary Framing Channel/Cable Runway	97
Clip J-Bolt, Auxiliary Framing Channel/Cable Runway	98
J-Bolt Kit, Auxiliary Framing Channel/Wall Angle Support	98
J-Bolts (Hook Bolt, Round Bend), Auxiliary Framing Channel/Cable	98

Cable Runway System

Universal-Style 250 Cable Runway

The maximum load capacity when supported every 5" with minimal deflection is 132 Lbs/ft. Welded steel tubing construction, individually boxed.

- Overall length = 10"
- Side stringer = 1.5" x 0.375" x 0.065" (38.1 mm x 9.52 mm x 1.65 mm)
- Cross member = 1.5" x 0.375" x 0.065" welded at 12" intervals
- Available in black (B) or white (W) powder coated finish

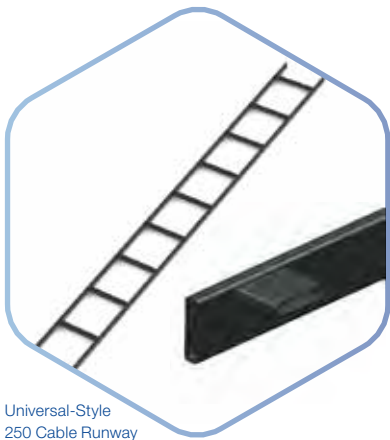

Universal-Style
250 Cable Runway

Black Finish	White Finish	Width	Shipping Weight
--------------	--------------	-------	-----------------

Universal-Style 250 Cable Runway

Black Finish	White Finish	Width	Shipping Weight
BLRS250-06B	BLRS250-06W	6" (152.4 mm)	19 Lbs (8.62 kg)
BLRS250-12B	BLRS250-12W	12" (304.8 mm)	24 Lbs (10.89 kg)
BLRS250-18B	BLRS250-18W	18" (457.2 mm)	28 Lbs (12.70 kg)
BLRS250-24B	BLRS250-24W	24" (609.6 mm)	32 Lbs (14.51 kg)
BLRS250-30B	BLRS250-30W	30" (762 mm)	37 Lbs (16.78 kg)
BLRS250-36B	BLRS250-36W	36" (914.4 mm)	42 Lbs (19.05 kg)

Telco-Style Cable Runway

The maximum load capacity when supported every 5" with minimal deflection is 132 Lbs/ft. Welded steel tubing construction, individually boxed.

- Overall length = 10"
- Side stringer = 1.5" x 0.375" x 0.065" (38.1 mm x 9.52 mm x 1.65 mm)
- Cross member = 0.5" x 1" x 0.065" welded at 9" intervals
- Available in black (B) or white (W) powder coated finish

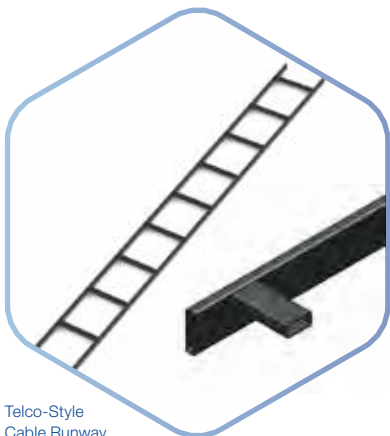

Telco-Style
Cable Runway

Black Finish	White Finish	Width	Shipping Weight
--------------	--------------	-------	-----------------

Telco-Style Cable Runway

Black Finish	White Finish	Width	Shipping Weight
BLRT252-06B	BLRT252-06W	6" (152.4 mm)	22 Lbs (9.98 kg)
BLRT252-12B	BLRT252-12W	12" (304.8 mm)	24 Lbs (10.89 kg)
BLRT252-18B	BLRT252-18W	18" (457.2 mm)	26 Lbs (11.79 kg)
BLRT252-24B	BLRT252-24W	24" (609.6 mm)	28 Lbs (12.70 kg)



UL Classified Cable Runway

The maximum load capacity when supported every 5" with minimal deflection is 132 Lbs/ft. Welded steel tubing construction, individually boxed.

- Overall length = 10"
- Side stringer = 1.5" x 0.375" x 0.065" (38.1 mm x 9.52 mm x 1.65 mm)
- Cross member = 0.5" x 1" x 0.065" welded at 9" intervals
- Available in black (B) or gold (G) chemical finish over zinc plating

Black Finish	Gold Finish	Width	Shipping Weight
--------------	-------------	-------	-----------------

UL Classified Style 275 Cable Runway

BLRU275-06B	BLRU275-06G	6" (152.4 mm)	19 Lbs (8.62 kg)
BLRU275-12B	BLRU275-12G	12" (304.8 mm)	24 Lbs (10.89 kg)
BLRU275-18B	BLRU275-18G	18" (457.2 mm)	28 Lbs (12.70 kg)
BLRU275-24B	BLRU275-24G	24" (609.6 mm)	32 Lbs (14.51 kg)

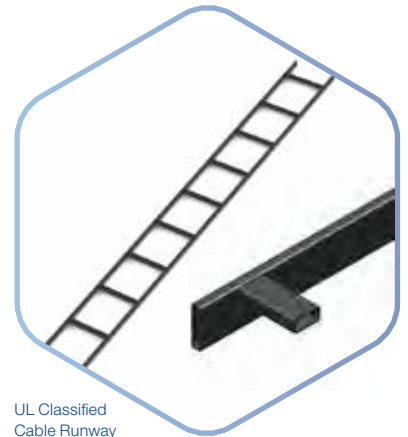

UL Classified Cable Runway

Quick Ship Cable Runway Bundle

Designed to meet UPS small package shipping requirements.

- (Qty = 2) 5" Universal cable runway; combined length is 10"
- (Qty = 1) Butt-Splice Kit Part Number BLBS301-15B
- Available in black (B)

Black Finish	Width	Shipping Weight
--------------	-------	-----------------

Quick Ship Cable Runway Bundle

BLRQ250-06B	6" (152.4 mm)	19 Lbs (8.62 kg)
BLRQ250-12B	12" (304.8 mm)	24 Lbs (10.89 kg)

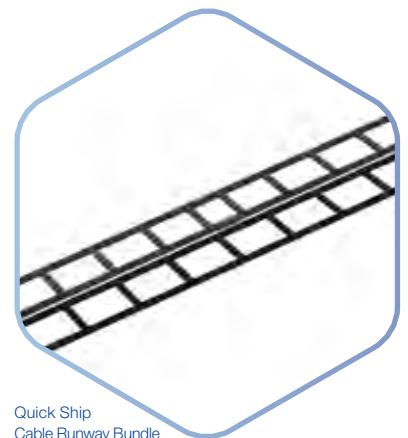

Quick Ship Cable Runway Bundle

Cable Runway Radius Bend

Creates a gradual bend for cascading cable runs.

- Made of 1.5" x 0.375" tubular steel
- Three cross members welded at approximately 23° increments
- Outside/inside is determined by welding cross members closer to cable side
- Available in black (B) or white (W) powder coated finish

Black Finish	White Finish	Width	Shipping Weight
--------------	--------------	-------	-----------------

Cable Runway Radius Bend

BLOR723-06B/BLIR724-06B	BLOR723-06W/BLIR724-06W	6" (152.4 mm)	3 Lbs (1.36 kg)
BLOR723-12B/BLIR724-12B	BLOR723-12W/BLIR724-12W	12" (304.8 mm)	4 Lbs (1.82 kg)
BLOR723-18B/BLIR724-18B	BLOR723-18W/BLIR724-18W	18" (457.2 mm)	5 Lbs (2.27 kg)
BLOR723-24B/BLIR724-24B	BLOR723-24W/BLIR724-24W	24" (609.6 mm)	6 Lbs (2.72 kg)
BLOR723-30B/BLIR724-30B	BLOR723-30W/BLIR724-30W	30" (762 mm)	7 Lbs (3.17 kg)
BLOR723-36B/BLIR724-36B	BLOR723-36W/BLIR724-36W	36" (914.4 mm)	8 Lbs (3.63 kg)



Cable Runway Radius Bend

Cable Runway System *(continued)*



Cable Runway E-Bend

Cable Runway E-Bend

Creates a 90° gradual sweep in horizontal plane for cable runway runs. Designed for cabling in conformance with minimum bend radius requirements (typically four times the cable diameter). Made of lightweight 1.5" x 0.375" tubular steel to fit standard cable runway.

- Cross members welded at approximately 23° increments
- Conforms to Category 5e/6A requirements
- Available in black (B) or white (W) powder coated finish

Black Finish	White Finish	Width	Shipping Weight
--------------	--------------	-------	-----------------

Cable Runway E-Bend

Black Finish	White Finish	Width	Shipping Weight
BLEB822-12B	BLEB822-12W	12" (304.8 mm)	12 Lbs (5.44 kg)
BLEB822-18B	BLEB822-18W	18" (457.2 mm)	19 Lbs (8.62 kg)
BLEB822-24B	BLEB822-24W	24" (609.6 mm)	27 Lbs (12.25 kg)



Movable Cross Member

Movable cross member allows for cable droppings combined with the radius drop where the cabinet or cable manager below does not align with the fixed cross member of the cable pathway.

- Fits on 12" and 18" cable pathway
- Can be used with Radius Drop Kit
- Includes hardware and bracket to mount to stringers
- Available in black (B) or white (W) powder coated finish

Black Finish	White Finish	Width	Shipping Weight
--------------	--------------	-------	-----------------

Movable Cross Member

Black Finish	White Finish	Width	Shipping Weight
BLMC115-12B	BLMC115-12W	12" (304.8 mm)	2 Lbs (0.91 kg)
BLMC115-18B	BLMC115-18W	18" (457.2 mm)	3.5 Lbs (1.59 kg)

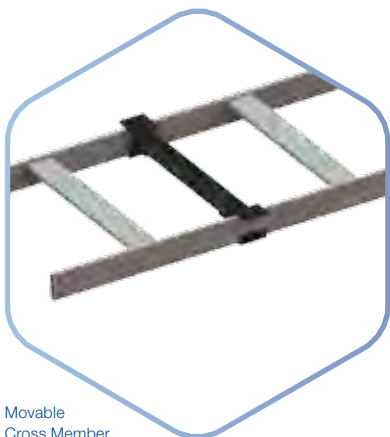

Movable Cross Member



Cable Runway Radius Drop

Mounts to the side stringer or cross member of cable runway to help maintain proper Category 5e/6/6A or fiber bend radius.

- Quick and easy installation
- Cross member radius drop (BLRRD100-XXX) fits 6", 12" and 18" W cross member tubing on Universal Runway (Series 250)
- Stringer Radius Drop (BLRRD101-XXX) attaches to the side of the runway
- Provides 3" bend radius
- Available in black (B)

Black Finish	Cable Runway Width	Product Width	Cable Spools
Cable Runway Radius Drop			
BLRRD100-06B	6" (152.4 mm)	5" (127 mm)	2 ea.
BLRRD100-12B	12" (304.8 mm)	11" (279.4 mm)	3 ea.
BLRRD100-18B	18" (457.2 mm)	17" (431.8 mm)	3 ea.
BLRRD101-11B	Universal	5" (127 mm)	2 ea.
BLRRD101-12B	Telco	8" (203.2 mm)	2 ea.
BLRRD101-13B	Misc.	11" (279.4 mm)	3 ea.



Cable Runway Radius Drop

Cable Spool Divider Kit

Separates cables for improved cable management. Bracket is mounted to cross sections anywhere you like from left to right. Kit includes 5 units. Cable spool is 4" tall made of plastic; bracket is made of steel.

- Available in black (B)

Black Finish	Used With	Qty/Kit
Cable Spool Divider Kit		
BLDU-05B	Universal Style 250 Runway	5 pcs
BLDT-05B	Telco Style 252 and UL Style 275 Runways	5 pcs



Cable Spool Divider Kit

Junction Kits

Butt-Splice Kit

Connect two sections of runway end-to-end. Fits both solid and tubular steel 1.5" x 0.375" and 2" x 0.375".

Kit consists of:

- (Qty = 4) splice plates
- (Qty = 2) 3/8"-16 trimmed head bolts
- (Qty = 2) 3/8"-16 hex nuts
- Available in black (B) and white (W) for non UL, available in black (B) and gold (G) for UL



Butt-Splice Kit

Black Finish	White Finish	Gold Finish	Description	Shipping Weight
Butt-Splice Kit				
BLBS301-15B	BLBS301-15W	-	1.5" x 0.375" (38.1 mm x 9.52 mm)	1 Lbs (0.45 kg)
BLBS301-20B	BLBS301-20W	-	2" x 0.375" (50.8 mm x 9.52 mm)	1 Lbs (0.45 kg)
BLBSU301-15B	-	BLBSU301-15G	1.5" x 0.375" (38.1 mm x 9.52 mm)	1 Lbs (0.45 kg)

Heavy-Duty Butt-Splice Kit

For butting two lengths of runway together. Cable runway drilling is required.

- Bolt through Butt-Splice Kit for earthquake areas

Kit consists of:

- (Qty = 4) splice plates for 1.5" stringers
- (Qty = 4) 3/8"-16 x 1.25" cap screws
- (Qty = 4) 3/8"-16 hex nuts
- Available in black (B)

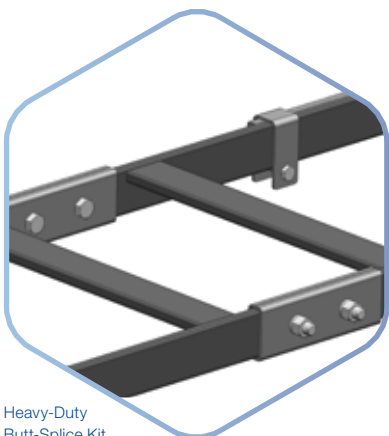

Heavy-Duty Butt-Splice Kit

Black Finish	Description	Shipping Weight
Heavy-Duty Butt-Splice Kit		
BLBSH299-15B	Heavy-Duty Butt-Splice Kit	3 Lbs (1.36 kg)
BLBSHU299-15B	UL Classified Butt-Splice Kit	3 Lbs (1.36 kg)





Junction-Splice Kit

Used to create a 90° junction splice with all types of 1.5" x 0.375" or 2" x 0.375" cable runway.

Kit consists of:

- (Qty = 4) corner clamp plates
- (Qty = 2) 3/8"-16 x 1" long trimmed head bolts
- (Qty = 2) 3/8"-16 hex nuts
- (Qty = 2) 3/8" split lock washers
- Available in black (B)

Black Finish	Description	Shipping Weight
Junction-Splice Kit		
BLJS302-15B	1.5" x 0.375" (38.1 mm x 9.52 mm)	1 Lbs (0.45 kg)
BLJS302-20B	2" x 0.375" (50.8 mm x 9.52 mm)	1 Lbs (0.45 kg)
BLJSU302-15B	1.5" x 0.375" (38.1 mm x 9.52 mm)	1 Lbs (0.45 kg)



Junction-Splice Kit

Heavy-Duty Junction-Splice Kit

Bolt-through Junction-Splice Kit for vertical runs or seismic requirements. Cable runway drilling is required.

- Material is 2" x 2" x 0.1875" steel angle

Kit consists of:

- (Qty = 2) splice angles
- (Qty = 4) 3/8"-16 x 1.25" hex cap screws
- (Qty = 4) 3/8"-16 hex nuts
- (Qty = 4) 3/8"-16 split lock washers
- Available in black (B)

Black Finish	Description	Shipping Weight
Heavy-Duty Butt-Splice Kit		
BLBSH299-15B	Heavy-Duty Butt-Splice Kit	3 Lbs (1.36 kg)
BLBSHU299-15B	UL Classified Butt-Splice Kit	3 Lbs (1.36 kg)



Heavy-Duty Butt-Splice Kit

Junction Kits *(continued)*



90°
Runway-Splice Kit

90° Runway-Splice Kit

Designed to butt splice 1.5" x 0.375" cable runway at a 90° angle.

Kit consists of:

- (Qty = 2) 90° outside clamps
- (Qty = 2) inside edge clamps
- (Qty = 2) 3/8"-16 x 2.50" trimmed round head, square neck bolts
- (Qty = 2) 3/8"-16 hex nut and lock washer
- Available in black (B)

Black Finish	Description	Shipping Weight
90° Runway-Splice Kit		
BLRSK314-90B	90° Runway-Splice Kit	1 Lbs (0.45 kg)
BLRSK314-9UB	90° Runway-Splice Kit UL Classified	1 Lbs (0.45 kg)



45°
Runway-Splice Kit

45° Runway-Splice Kit

Designed to butt splice 1.5" x 0.375" cable runway at a 45° angle.

Kit consists of:

- (Qty = 2) 45° outside clamps
- (Qty = 2) inside edge clamps
- (Qty = 2) 3/8"-16 trimmed round head, square neck bolts
- Available in black (B)

Black Finish	Description	Shipping Weight
45° Runway-Splice Kit		
BLRSK313-45B	45° Runway-Splice Kit	1 Lbs (0.45 kg)
BLRSK313-4UB	45° Runway-Splice Kit UL Classified	1 Lbs (0.45 kg)



Adjustable
Junction-Splice Kit

Adjustable Junction-Splice Kit

Designed for use with 1.5" x 0.375" cable runway, adjusts to form any junction angle, electrical, etc.

Kit consists of:

- (Qty = 4) adjustable corner plates
- (Qty = 2) 3/8"-16 x 2" hex cap screws
- (Qty = 2) 3/8"-16 hex nuts
- (Qty = 2) 3/8"-16 split lock washers
- Available in black (B)

Black Finish	Description	Shipping Weight
Adjustable Junction-Splice Kit		
BLAJS616-00B	Adjustable Junction-Splice Kit	2 Lbs (0.91 kg)

Note: Requires one kit to attach one end of cable runway



Swivel Splice Kits

Splices cable runway vertically, horizontally or perpendicularly. Adjusts to any angle, not limited to 45° or 90°. Flexible swivel design simplifies cable runway installation by making it easier to route around existing plumbing, electrical, etc. Steel material. Hardware and instructions are included.

Butt-Swivel (487)

Kit consists of:

- (Qty = 8) bracket ends
- (Qty = 8) 5/16"-18 x 0.75" round head square, neck bolts
- (Qty = 2) 5/16"-18 x 1" round head square, neck bolts
- (Qty = 10) 5/16"-18 x 1" hex nuts, split lock washers
- Available in black (B)

Junction-Swivel (488)

Kit consists of:

- (Qty = 4) bracket ends
- (Qty = 2) bracket supports and plate clamps
- (Qty = 2) 5/16"-18 x 1" round head square, neck bolts
- Qty = 8) 5/16"-18 x 0.75" round head square, neck bolts
- (Qty = 10) 5/16"-18 hex nut, split lock washers
- Available in black (B)

Vertical-Swivel (489)

Kit consists of:

- (Qty = 4) bracket ends
- (Qty = 2) bracket clamps and plate clamps
- (Qty = 2) 5/16"-18 x 1" round head, square neck bolts
- (Qty = 6) 5/16"-18 x 0.75" round head, square neck bolts
- (Qty = 8) 5/16"-18 hex nuts, split lock washers
- Available in black (B)



Butt Swivel



Junction Swivel



Vertical Swivel

Black Finish	Description	Shipping Weight
Swivel Splice Kits		
BLBSS487-00B	Butt-Swivel Splice Kit	1 Lbs (0.45 kg)
BLJSS488-00B	Junction-Swivel Splice Kit	1 Lbs (0.45 kg)
BLVBS489-00B	Vertical-Swivel Splice Kit	1 Lbs (0.45 kg)
BLBSS487-0UB	UL Classified Butt-Swivel Splice Kit	1 Lbs (0.45 kg)
BLBSS488-0UB	UL Classified Junction-Swivel Splice Kit	1 Lbs (0.45 kg)
BLVBS489-0UB	UL Classified Vertical-Swivel Splice Kit	1 Lbs (0.45 kg)

Junction Kits *(continued)*

Cable Runway Corner Bracket

Creates a radius for L-, T- or X-shaped intersections of cable runway formed when two or more pieces of cable runway are connected together with the Junction-Splice Kit (BLJS302-15B or BLJSU302-15B) or Heavy-Duty Junction-Splice Kit (BLJSH298-15B).

- Single-piece welded assembly fabricated from 0.375" x 1.5" x 0.065" wall rectangular steel tubing
- Easy installation; brackets/hardware included
- Available in black (B) or white (W) powder coated finish



Cable Runway
Corner Bracket

Finish	DIM	Description	Shipping Weight
Cable Runway Corner Bracket			
Black Finish			
BLCSB959-15B	A/B	15" Corner Bracket	4 Lbs (1.82 kg)
BLCSB959-24B	A/B	24" Corner Bracket	6 Lbs (2.72 kg)
White Finish			
BLCSB959-15W	–	15" Corner Bracket	4 Lbs (1.82 kg)
BLCSB959-24W	–	24" Corner Bracket	6 Lbs (2.72 kg)

Cable Runway Closing Kit

The cable runway closing kit is used to close the end of a runway. Compatible with Universal style 250, Telco style 252 and UL style 275.

Kit consists of:

- (Qty = 1) end closing bar
- (Qty = 4) corner clamp plates
- (Qty = 2) 3/8"-16 x 1.25" bolts
- (Qty = 2) 3/8" hex nuts
- Available in black (B), white (W) or gold (G) chemical finish over zinc plating

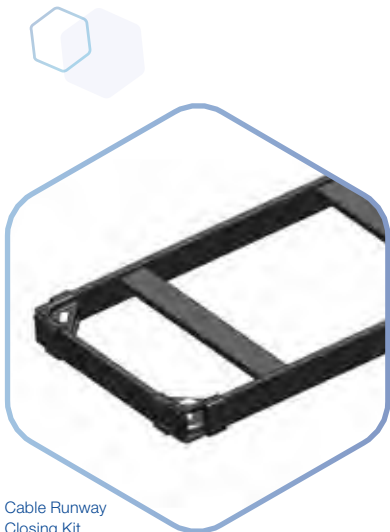

Cable Runway
Closing Kit

Black Finish	White Finish	Gold Finish	Width	Shipping Weight
Cable Runway Closing Kit				
BLCCKE700-06B	BLCCKE700-06W	BLCCKE700-06G	6" (152.4 mm)	2 Lbs (0.91 kg)
BLCCKE700-12B	BLCCKE700-12W	BLCCKE700-12G	12" (304.8 mm)	3 Lbs (1.36 kg)
BLCCKE700-18B	BLCCKE700-18W	BLCCKE700-18G	18" (457.2 mm)	4 Lbs (1.82 kg)
BLCCKE700-24B	BLCCKE700-24W	BLCCKE700-24G	24" (609.6 mm)	5 Lbs (2.27 kg)



Cable Runway End Cap

Covers, protect exposed end of runway. Compatible with Universal style 250, Telco style 252 and UL style 275. Black, plastic material.

Kit consists of:

- (Qty = 2) end CAP

Black Finish	Description (Used With:)	Shipping Weight
Cable Runway End Cap		
BLPEC642-002	Protective End Caps for 1.5" x 0.375" Stringer (Pair)	1 Lbs (0.45 kg)



Cable Runway End Cap

Retaining Post For Cable

The retaining post is compatible with Universal, Telco and UL runways and allow for extra cable routing capacity.

Kit consists of:

- (Qty = 1) Post, bracket, and end cap
- (Qty = 1) 1/4"-20 x 1.25" hex cap screw, split lock washer and hex nut
- Available in black (B)

Black Finish	Description	Shipping Weight
Retaining Post For Cable		
BLCRP596-06B	Cable Retaining Post, 6", Qty = 1	1 Lbs (0.45 kg)
BLCRP596-56B	Cable Retaining Post, 6", Qty = 50	29 Lbs (13.15 kg)



Retaining Post for Cable



Support Brackets

Cable Runway Wall to Rack Kit

The Belden cable runway Wall to Rack Kit is a one-part-number solution that provides support for cable between the rack and the wall.

Kit consists of:

- (Qty = 1) 54" cable runway
- (Qty = 1) Wall angle support bracket
- (Qty = 1) Rack to runway mounting plate
- (Qty = 1) Pair of end caps
- (Qty = 3) J-bolt kits (BLJBK-001)
- Available in black (B) or white (W) powder coated finish



Cable Runway
Wall to Rack Kit

Black Finish	White Finish	Description	Shipping Weight
--------------	--------------	-------------	-----------------

Cable Runway Wall to Rack Kit

BLRW250-06B	BLRW250-06W	6" (152.4 mm)	16 Lbs (7.26 kg)
BLRW250-12B	BLRW250-12W	12" (304.8 mm)	19 Lbs (8.62 kg)

Compatible with 3" wide upright equipment rack

Wall Angle Support Kit, Cable Runway

2" x 2" x 3/16" (7 Gauge) steel support angle is designed for wall-mounting specific widths of cable runway.

Kit consists of:

- (Qty = 1) wall angle
- (Qty = 2) 5/16"-18 x 2.25" J-bolts
- (Qty = 2) 5/16"-18 hex nuts
- (Qty = 2) 5/16" lock washers
- Available in black (B)

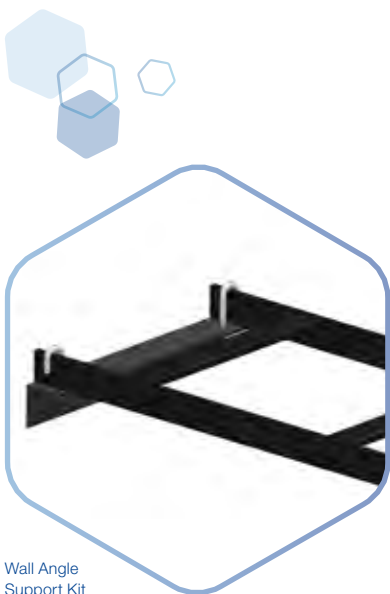

Wall Angle
Support Kit

Black Finish	Width	Shipping Weight
--------------	-------	-----------------

Wall Angle Support Kit, Cable Runway

BLWAS421-06B	6" (152.4 mm)	2 Lbs (0.91 kg)
BLWAS421-12B	12" (304.8 mm)	3 Lbs (1.36 kg)
BLWAS421-18B	18" (457.2 mm)	5 Lbs (2.27 kg)
BLWAS421-24B	24" (609.6 mm)	6 Lbs (2.72 kg)



Triangular Support Bracket, Aluminum

Provides wall support for cable runway. Made of 0.25" x 2" aluminum bar, Load rating is 100 Lbs.

Kit consists of:

- (Qty = 1) triangular bracket
- (Qty = 2) 5/16"-18 x 2.25" J-bolts
- (Qty = 2) 5/16"-18 hex nuts and split washers
- Available in black (B)

Black Finish	Width	Shipping Weight
Triangular Support Bracket, Aluminum		
BLTSB312-06B	4" to 6" (101.6 to 152.4 mm)	2 Lbs (0.91 kg)
BLTSB312-12B	6" to 12" (152.4 mm to 304.8 mm)	3 Lbs (1.36 kg)
BLTSB312-18B	12" to 18" (304.8 mm to 457.2 mm)	3 Lbs (1.36 kg)



Triangular Support Bracket, Aluminum

Triangular Support Bracket, Steel

Provides wall support for cable runway. Made of cold-rolled steel, Load rating is 400 Lbs.

Kit consists of:

- (Qty = 1) vertical wall-mounting bracket
- (Qty = 1) runway support channel
- (Qty = 1) angle support channel
- (Qty = 3) clevis pins (5/16" diameter) and cotter pins
- (Qty = 2) 5/16"-18 x 2.25" J-bolts
- (Qty = 2) 5/16"-18 x hex nuts and split washers
- Available in black (B)h

Black Finish	Width	Shipping Weight
Triangular Support Bracket, Steel		
BLTSB746-12B	6" to 12" (152.4 to 304.8 mm)	5 Lbs (2.27 kg)
BLTSB746-18B	18" (457.2 mm)	8 Lbs (3.63 kg)
BLTSB746-24B	24" (609.6 mm)	9 Lbs (4.08 kg)



Triangular Support Bracket, Steel



Support Brackets *(continued)*



3" Channel Rack-to-Runway Mounting Plate

3" Channel Rack-to-Runway Mounting Plate

Secures cable runway to the top of standard rack and universal rack. Mounts either parallel or perpendicular.

- Material is 11 gauge steel, Installation best practice includes Runway Elevation Kit.

Kit consists of:

- (Qty = 1) mounting plate
- (Qty = 4) 5/16"-18 x 2.25" J-bolts
- (Qty = 4) 5/16"-18 hex nuts
- (Qty = 4) 5/16" split lock washer
- Available in black (B)

Black Finish	Width	Shipping Weight
3" Channel Rack-to-Runway Mounting Plate		
BLRTR595-9B	9" to 12" (228.6 to 304.8 mm)	3 Lbs (1.36 kg)
BLRTR595-15B	15" to 18" (381 mm to 457.2 mm)	4 Lbs (1.82 kg)



Cable Runway Elevation Kit

Supports cable runway above a continuous row of two and four post racks or cabinets of varying heights, and provides additional space between the tops of the racks or cabinets and the cable runway, which can create smoother cable transitions.

- Three ranges of incremental elevation
- Can be mounted perpendicular or parallel
- Rack kit includes a single pair of brackets and assembly hardware
- Rack kits attach to the top of the rack with a Rack-to-Runway

Mounting Plate (BLRTR595-9B, -15B), sold separately

- Cabinet kits include two pairs of brackets and assembly hardware
- Cabinet kits attach directly to the top of the cabinet
- Available in black (B)



Cable Runway Elevation Kit

Rack Black Finish	Cabinet White Finish	Description	Shipping Weight
Cable Runway Elevation Kit			
BLREK506-02B	BLREK506-12B	2", 2.5", 3" (50.8 mm, 63.5 mm, 76.2 mm)	2 Lbs (0.91 kg)
BLREK506-04B	BLREK506-16B	4", 5", 6" (101.6 mm, 127 mm, 152.4 mm)	2.4 Lbs (1.09 kg)
BLREK506-10B	BLREK506-18B	10", 11", 12" (254 mm, 279.4 mm, 304.8 mm)	3 Lbs (1.36 kg)



Cable Runway Standoff Support Kit

Allows the attachment of cable runway 12" directly above and either parallel or perpendicular to existing cable runway. Each kit consists of the following items: two steel angle pieces, four steel brackets and eight sets of nuts, bolts and washers. The angle pieces are black.

Black Finish	Description	Shipping Weight
Cable Runway Standoff Support Kit		
BLRSS470-12B	12" (304.8 mm)	1 Lbs (0.45 kg)

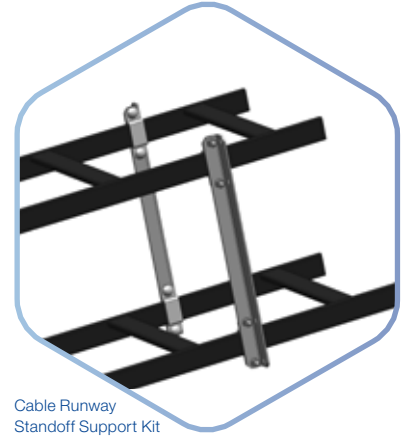

Cable Runway Standoff Support Kit

Vertical Wall Brackets

Used to secure Cable Runway with 1.5" x 3/8" stringers to a wall. Sold in pairs.

- Wall mounting hardware not included
- Available in black (B)

Black Finish	Description	Shipping Weight
Vertical Wall Brackets		
BLVWB608-00B	Vertical Wall Bracket, Pair	1 Lbs (0.45 kg)



Vertical Wall Brackets

Cable Runway Pipe Stand

Pipe stand allow support of runway from the floor.

Kit consists of:

- (Qty = 1) floor flange
- (Qty = 1) appropriate length of 2" pipe
- (Qty = 1) pipe cap, center drilled and tapped for a 5/8"-11 threaded rod (BLTR440, not included)
- (Qty = 3) 5/8"-11 hex nuts
- (Qty = 3) 5/8" split lock washers
- (Qty = 4) 1/4"-20 x 1.5" studs
- (Qty = 4) 1/4"-20 concrete anchors
- (Qty = 4) 1/4"-20 hex nuts
- (Qty = 4) 1/4" type B washer
- Available in black (B)

Black Finish	Height	Shipping Weight
Cable Runway Pipe Stand		
BLPSR684-79B	79" (2006.6 mm)	16 Lbs (7.26 kg)
BLPSR684-85B	85" (2159 mm)	18 Lbs (8.16 kg)
BLPSR684-91B	91" (2311.4 mm)	20 Lbs (9.07 kg)

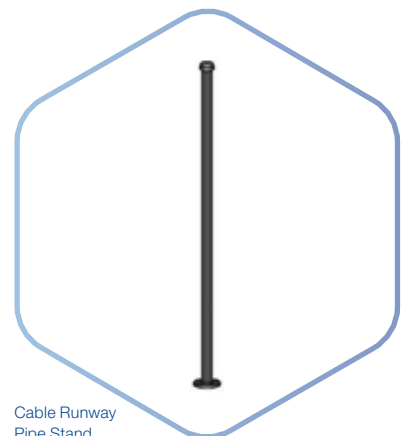

Cable Runway Pipe Stand

Support Brackets *(continued)*

Framing Clamp Kit

Allows runway attachment to pipe stand.

- Include a pair of bracket and hardware
- To install, you will need 5/8" threaded rod (BLTR440-002)
- Available in black (B)



Framing
Clamp Kit

Black Finish	Description	Shipping Weight
Framing Clamp Kit		
BLCBK609-001B	Clamp Bracket Kit, Pair	0.3 Lbs (0.14 kg)

Runway Center Support Kit

Used to attach cable runway to auxiliary framing.

Kit consists of:

- (Qty = 1) support bracket
- (Qty = 1) reinforcement bar
- (Qty = 2) 5/8"-11 hex nuts
- (Qty = 1) 5/8"-11 split lock washers
- (Qty = 1) 12" L threaded rod cover
- (Qty = 1) J-bolt kit (2 J-bolts; 2 nuts; 2 washers)
- Available in black (B)

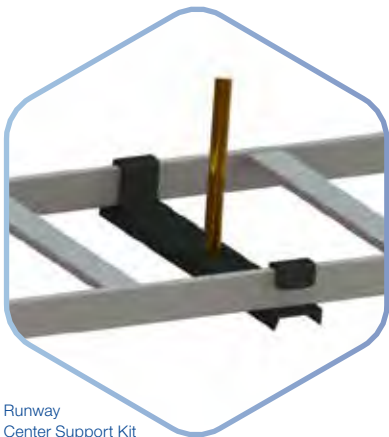

Runway
Center Support Kit

Black Finish	Description	Shipping Weight
Runway Center Support Kit		
BLCCK362-06B	6" (152.4 mm)	2 Lbs (0.91 kg)
BLCCK362-12B	12" (304.8 mm)	3 Lbs (1.36 kg)
BLCCK362-18B	18" (457.2 mm)	4 Lbs (1.82 kg)
BLCCK362-24B	24" (609.6 mm)	5 Lbs (2.27 kg)

Note: Kit does not include threaded rod





Ceiling Attachment Kit

The ceiling attachment kit is used to suspend the runway from the ceiling, Made of steel with gold over zinc plated plating finish.

Kit consists of:

- (Qty = 1) ceiling bracket
- (Qty = 1) 3/8"-16 x 6" or 5/8"-11 x 6" rod
- (Qty = 1) Support bracket for compatible with type 250, 252, 275 style runway
- (Qty = 4) 3/8"-16 or 5/8"-11 hex nuts

Gold Finish	Description	Shipping Weight
Ceiling Attachment Kit		
BLTCK310-38	3/8"	3 Lbs (1.36 kg)
BLTCK310-58	5/8"	7 Lbs (3.18 kg)

Note: The recommended spacing between the ceiling attachment kit is 5" . The ceiling hole diameter is 0.375" (9.52 mm) for 0.375" (9.52 mm) rod kit and 0.500" (12.7 mm) for 0.625" (15.87 mm) kit.



Ceiling Attachment Kit

Support Bracket for Runway

Used do secure threaded rod to runway.

- Available in black (B)

Black Finish	Description	Shipping Weight
Support Bracket for Runway		
BLRSB408-038B	3/8" (9.52 mm)	0.1 Lbs (0.04 kg)
BLRSB408-058B	5/8" (15.87 mm)	0.1 Lbs (0.04 kg)

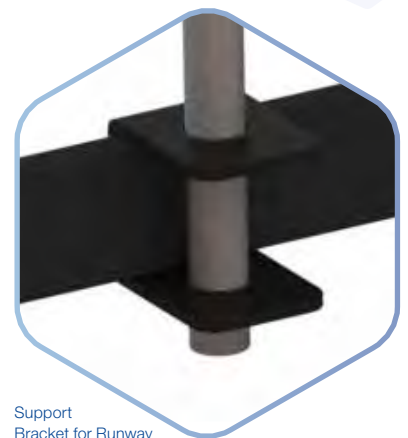

Support Bracket for Runway

Ceiling Support Bracket

Used do secure threaded rod to ceiling.

- Available in black (B)

Black Finish	Description	Shipping Weight
Ceiling Support Bracket		
BLCSB406-038B	3/8"	1 Lbs (0.45 kg)
BLCSB406-058B	5/8"	1 Lbs (0.45 kg)

Note: hardware not included



Ceiling Support Bracket

Support Brackets *(continued)*



Threaded Rods

Threaded Rods

Use to suspend runway from the ceilings.

- Gold over zinc plating

Gold Finish	Description	Shipping Weight
Threaded Rods		
BLTR440-001	3/8" (0.52 mm) - 16 UNC, 6" (152.4 mm) long	2 Lbs (0.91 kg)
BLTR440-003	3/8" (0.52 mm) - 16 UNC, 12" (304.8 mm) long	5 Lbs (2.27 kg)
BLTR440-002	5/8" (15.87 mm) - 11 UNC, 6" (152.4 mm) long	5 Lbs (2.27 kg)
BLTR440-004	5/8" (15.87 mm) - 11 UNC, 12" (304.8 mm) long	10 Lbs (4.53 kg)

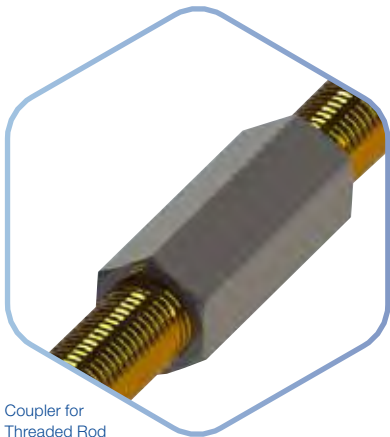

Coupler for Threaded Rod

Coupler for Threaded Rod

Allow coupling of two threaded rod.

Part Number	Description	Shipping Weight
Coupler for Threaded Rod		
BLCR697-038	3/8" - 16" (406.4 mm)	0.3 Lbs (0.14 kg)
BLCR697-058	5/8" - 11" (279.4 mm)	0.3 Lbs (0.14 kg)



Threaded Rods Cover

Threaded Rods Cover

Use to cover threaded rods and protect cables.

- Black plastic tubing, ID = 0.630" (16 mm)

Part Number	Description	Shipping Weight
Threaded Rods Cover		
BLTRC085-010	10" (254 mm)	5 Lbs (2.27 kg)



J-Bolt Kit, Auxiliary Framing Channel/Rack Top Bar

Used to attach a 2" x 1" auxiliary framing channel to a 1.5" equipment rack top bar.

- Gold over zinc plating

Kit consists of:

- (Qty = 1) 1/4" x 1" x 3.5" cold-rolled steel plate
- (Qty = 2) 5/16"-18 x 3.25" J-bolts
- (Qty = 2) 5/16"-18 hex nuts and split lock washers

Gold Finish	Description	Shipping Weight
J-Bolt Kit, Auxiliary Framing Channel/Rack Top Bar		
BLJBK-002	J-Bolt Kit	1 Lbs (0.45 kg)

J-Bolt Clip Kit, Auxiliary Framing Channel/Cable Runway

For fastening cable runway to auxiliary framework. Material is steel finished.

- Gold over zinc plating

Kit consists of:

- (Qty = 2) clip J-bolt
- (Qty = 2) 1/2"-13 split lock washer
- (Qty = 2) 1/2"-13 hex nut

Gold Finish	Description	Shipping Weight
J-Bolt Clip Kit, Auxiliary Framing Channel/Cable Runway		
BLJBC-001	3/8" x 2" (9.52 x 50.8 mm)	1 Lbs (0.45 kg)
BLJBC-002	5/8" x 2" (15.87 x 50.8 mm)	1 Lbs (0.45 kg)
BLJBC-003	1" x 2" (25.4 x 50.8 mm)	1 Lbs (0.45 kg)



J-Bolt Kit,
Auxiliary Framing
Channel/Rack Top Bar

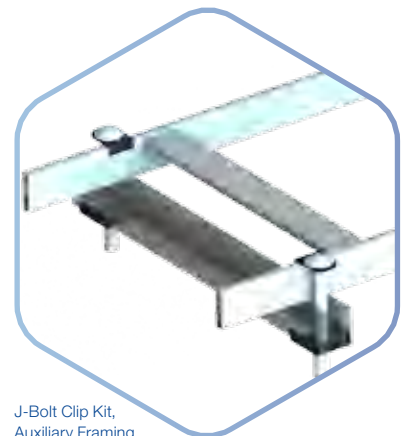

J-Bolt Clip Kit,
Auxiliary Framing
Channel/Cable Runway

Support Brackets *(continued)*



Clip J-Bolt,
Auxiliary Framing
Channel/Cable Runway

Clip J-Bolt, Auxiliary Framing Channel/Cable Runway

Used to attach cable runway to auxiliary framing.

- Sold individually
- Gold over zinc plating

Kit consists of:

- (Qty = 1) 1/2"-13 lock nut
- (Qty = 1) 1/2" split lock washer

Gold Finish	Description	Shipping Weight
-------------	-------------	-----------------

Clip J-Bolt, Auxiliary Framing Channel/Cable Runway

BLJBC-004	1/2"-13 x 4.375" (12.7 mm - 13 x 111.12 mm)	1 Lbs (0.45 kg)
BLJBC-005	1/2"-13 x 4.875" (12.7 mm - 13 x 123.82 mm)	1 Lbs (0.45 kg)



J-Bolt Kit,
Auxiliary Framing
Channel/Wall Angle Support

J-Bolt Kit, Auxiliary Framing Channel/Wall Angle Support

Used to attach a 2" x 1" auxiliary framing channel to a wall angle support.

- Gold over zinc plating

Kit consists of two each:

- 1/4"-20 x 1.75" J-bolts
- 1/4"-20 hex nuts
- 1/4" split lock washers

Gold Finish	Description	Shipping Weight
-------------	-------------	-----------------

J-Bolt Kit, Auxiliary Framing Channel/Wall Angle Support

BLJBK-001	J-Bolt Kit	1 Lbs (0.45 kg)
-----------	------------	-----------------





J-Bolts (Hook Bolt, Round Bend), Auxiliary Framing Channel/Cable

Used to bolt cable runway, auxiliary framing channels and/or bars together.

- Gold over zinc and black zinc plate finish
- Includes nut and split lock washer
- Commercial grade, kits sold individually

Gold/Black Finish	Nominal Size	Length	Opening	Shipping Weight
-------------------	--------------	--------	---------	-----------------

J-Bolts (Hook Bolt, Round Bend), Auxiliary Framing Channel/Cable

BLJB-001	1/4"-20	1.75" (44.45 mm)	7/32" (5.56 mm)	1 Lbs (0.45 kg)
BLJB-002	1/4"-20	2" (50.8 mm)	7/32" (5.56 mm)	1 Lbs (0.45 kg)
BLJB-003	5/16"-18	2.25" (57.15 mm)	7/16" (11.11 mm)	1 Lbs (0.45 kg)
BLJB-004	5/16"-18	2.75" (69.85 mm)	7/16" (11.11 mm)	1 Lbs (0.45 kg)
BLJB-005	5/16"-18	3.25" (82.55 mm)	7/16" (11.11 mm)	1 Lbs (0.45 kg)
BLJB-006	5/16"-18	3.75" (95.25 mm)	7/16" (11.11 mm)	1 Lbs (0.45 kg)
BLJB-007	5/16"-18	3.75" (95.25 mm)	7/16" (11.11 mm)	1 Lbs (0.45 kg)
BLJB-008	5/16"-18	6.20" (157.48 mm)	7/16" (11.11 mm)	1 Lbs (0.45 kg)



J-Bolts
(Hook Bolt, Round Bend), Auxiliary Framing Channel/Cable



BELDEN
SENDING ALL THE RIGHT SIGNALS





Warranty

■ Warranty

Warranty

102 - 103



Warranty

Limited Warranty

Belden warrants that, for a period of one (1) year following the date of delivery to the original customer, the products it offers for sale in the catalog are free from material defects in material and workmanship. The foregoing warranty is subject to the terms, limitations and conditions set forth below.

All PDUs and Accessories – Standard

One Year Warranty

This warranty does not include damage to the product resulting from accident or misuse, including exposure to water or any other corrosive material. This warranty excludes damage to equipment if surge or spike reaches that equipment through an unprotected source connected to it (i.e., printer, modem, phone line, etc.). It shall not apply to any product, which has been connected, installed, used or otherwise adjusted other than in accordance with written instructions furnished by BELDEN.

WARRANTY WILL BE VOIDED IF THE UNITS ARE OPENED, MODIFIED OR ALTERED DURING THE WARRANTY PERIOD.

Containment and Cooling Warranty

BELDEN warrants Containment and Cooling products for a period of one (1) year following the date of delivery. If the BELDEN product becomes defective during the one (1) year warranty period, BELDEN will elect to either repair or replace the unit free of charge. This warranty does not include damage to the product resulting from accident or misuse, including exposure to water or any other corrosive material.

WARRANTY WILL BE VOIDED IF THE UNITS ARE OPENED, MODIFIED OR ALTERED DURING THE WARRANTY PERIOD.

Powerstrip Warranty

If a BELDEN power strip product becomes defective during the warranty period listed below, BELDEN will elect to either repair or replace the unit free of charge.



Repairs or Adjustments

Belden, at its discretion, will make any repairs or adjustments to any products that are due to defects and/or workmanship. The warranties provided above (the “Warranties”) do not extend to any items that upon inspection by Belden are deemed to have been misused, neglected, improperly treated, improperly installed, or used in violation of instructions or specifications approved by Belden, or otherwise handled, installed, shipped or used in violation of industry standards for metal fabrication and solid state electronic equipment.

Limitation of Liability

Belden’s sole liability under any of the Warranties will be to repair or replace, at its discretion, products that do not meet the specifications and descriptions provided in the catalog or purchase order due to defects in material and workmanship. To the maximum extent permitted by law, under no circumstances shall Belden be liable for any consequential, special, or other indirect damages (including, but not limited to lost profits) for breach of this warranty. Belden’s total liability under any of the Warranties shall be limited to the price actually paid by the customer for the product(s) covered. Except as specifically set forth above, Belden expressly disclaims any other representation or warranties of any kind, expressed or implied, arising by law or custom, with respect to products set forth in the catalog or otherwise sold by Belden, including without limitation, warranties or merchantability, fitness for a particular purpose, non-infringement or any other matter.

Conditions of Warranty

The foregoing Warranties apply only to standard products set forth in the catalog. Custom products are covered by warranties stated in the Terms and Conditions of Sale of Belden’s quotation at the time of the order.

GLOBAL LOCATIONS

For more information, please visit us at:
www.beldensolutions.com



Be certain
you stay
in touch.

EUROPE/MIDDLE EAST/AFRICA

Germany

Phone: +49-7127-14-0
venlo.salesinfo@belden.com

France

Phone: +33-472-109-990
lyon.salesinfo@belden.com

Italy

Phone: +39-039-5965-250
info.milano@belden.com

Russia

Phone: +7-495-787-06-55
info@belden.ru

Spain

Phone: +34-91-746-17-30
madrid.salesinfo@belden.com

Sweden

Phone: +46-40-699-88-60
venlo.salesinfo@belden.com

The Netherlands

Phone: +31-773-878-555
venlo.salesinfo@belden.com

United Arab Emirates

Phone: +971-4-391-0490
dubai.salesinfo@belden.com

United Kingdom

Phone: +44-161-49837-49
manchester.salesinfo@belden.com

AMERICAS

USA

Phone: +1-800-BELDEN1
(1-800-235-3361)

ASIA/PACIFIC

Singapore

Phone: +65-6879-9800
apac.ecsmarketing@belden.com

China

Phone: +86-21-5445-2388
apac.ecsmarketing@belden.com

Belden, Belden Sending All The Right Signals, GarrettCom, Hirschmann, Lumberg Automation, Tofino Security, Tripwire and the Belden logo are trademarks or registered trademarks of Belden Inc. or its affiliated companies in the United States and other jurisdictions. Belden and other parties may also have trademark rights in other terms used herein.